

MODELS 35-VCB and 35-VCF GLASS FRONT MERCHANDISER ILLUSTRATED PARTS MANUAL

LOO89, REV. D

AUTOMATED MERCHANDISING SYSTEMS INC
255 WEST BURR BLVD.
KEARNEYSVILLE, WV 25430
304-725-6921 - Fax 304-725-6983

info@amsvendors.com
www.amsvendors.com

INTERNATIONAL A.M.S. S DE RL DE CV
KM. 9 CARR. AL CASTILLO NO. 8200
MPIO. DE EL SALTO, JAL. MEXICO 45680
5233-3-6-88-07-17 - Fax 5233-3-6-88-13-14

www.amsint.com.mx
servicio@amsint.com.mx

AMS Glass Front Merchandiser
Models 35-VCB and 35-VCF
Illustrated Parts Manual

Table of Contents

<u>SECTION</u>	<u>PAGE</u>
INTRODUCTION	
Table of Contents	3
General Introduction	4
Manual Organization	4
Merchandiser Identification	5
Patent Disclosure	6
Publication Notice	6
CABINET PARTS	
Cabinet Covers and Screens	8
Cabinet and Parts Assembled for VCB and VCF Vendor	10
CHILLER	
Chiller Parts – Side View	14
Chiller Parts – Top View	16
DOOR PARTS	
Door, Coin Bay	18
Door, External Front and Sides	20
Door, Hinges and Glass	24
Door, Hopper with Sensit II System	26
POS Display	28
ELECTRICAL HARNESSSES	30
TRAYS AND PARTS	
1.5” Helix Tray	46
Bottle Trays	48
Helixes	50
Universal (Food/Snack/Candy) Trays	52

GENERAL INTRODUCTION

The purpose of this manual is to give our customers a way of identifying major service parts for repair and replacement. The illustrations and parts list in this manual are for identification only. Some optional parts are also shown.

Illustrations of these major parts are keyed with our part numbers. The illustrations help identify the general design, position and orientation of these parts. The note section may also give important information.

Please refer to the section on merchandiser identification on the following pages. Without the model style and serial number it may be difficult to identify the required part.

Parts should be ordered from your distributor.

It is our intent to assist our customers with up-to-date documentation. However, this manual may not show all parts, variations or changes. Some parts may be shown out of scale. This manual is itself subject to change without notice. If any errors are found, please notify AMS so the correction can be included in later revisions. Engineering data and third party information are generally not included. The graphical data, group assembly data, parts, part assembly, parts breakout information and tabular data conveyed by this manual is proprietary and belongs to AMS, and holders without prior consent of or without knowledge of and by AMS must surrender this data immediately.

All measurements are in inches except where specified as Metric.

MANUAL ORGANIZATION

This manual is divided into general sections. Each section is further divided into the various subsections or subassemblies. These lead off with one or more illustrations showing the parts and each part is identified with a number. Note that some part numbers are for assemblies fabricated as a unit at AMS and are replaceable only as a unit. Also, other part numbers identify optional parts which may or may not have been contracted for and factory installed by AMS.

The part number in the illustration is listed with the description or title for that part. In some instances there may be multiple parts to choose from. The correct service or repair part for the style of merchandiser must be selected. A quantities column in the list indicates quantities required.

There is a note section where additional information may be found.

This manual contains additional and new information for a vendor as currently manufactured. Older revisions of this manual should be kept with older vendors.

MERCHANDISER IDENTIFICATION

When requesting service, replacement parts or technical assistance, please use the **Model Number** and the **Serial Number with Date Code**, found on the Serial Plate (Refer to Figure 1) affixed to the merchandiser. The plate is usually located inside the window. The information contained on this plate is necessary to determine what parts, kits, or maintenance apply to your vendor.

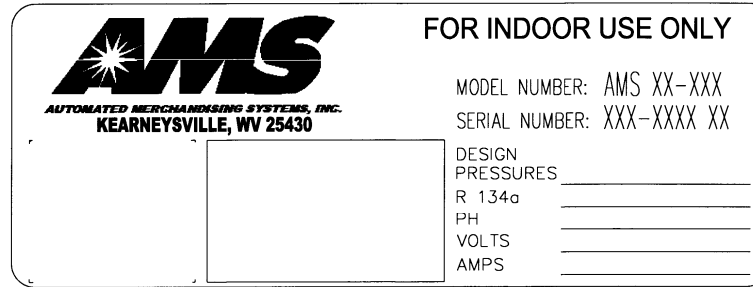

72-002 Serial Plate

Figure 1. Example of Typical Serial Plate

Example of Model Number Breakdown

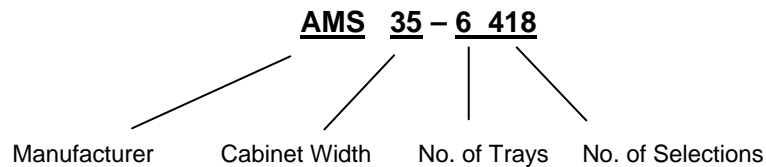

Example: AMS35-6-418 means this vendor is an Automated Merchandising Systems merchandiser, **35"** wide, with six (**6**) trays making available four hundred eighteen (**418**) positions for different products.

Example of Serial Number and Date Code Breakdown

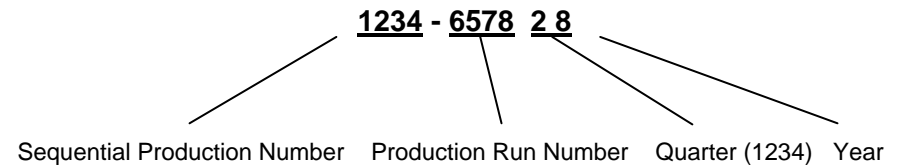

Example: 1243-5678-28 is translated as U.S. built **1** machine number **243** on production run number **5678** manufactured in the second quarter (**2**) of **2008**.

The Sequential Production Number of machines built in the U.S. starts with the number **1** or any odd number. The Sequential Production Number of machines built in Mexico starts with the number **0** or any even number.

PATENT DISCLOSURE

This merchandiser and/or certain of its components are covered by one or more of the following U.S. and international patents;

U.S. PATENTS: 6,041,962; 6,145,699; 6,202,888; 6,384,402; 6,520,373; 6,708,079; 6,794,634; 7,191,915;
7,446,302; 7,343,220; 7,742,837.

CANADIAN PATENT: 2,329,314.

MEXICO PATENT: 230714.

PUBLICATION NOTICE

L0089, Revision D, ECN 2436, 07/30/10

It is our intent to assist our customers with up-to-date documentation: however, this manual may not contain all updates and is subject to revision without notice. Please contact our Service Department with your requests or comments.

THIS PAGE INTENTIONALLY LEFT BLANK

CABINET COVERS AND SCREENS ILLUSTRATION

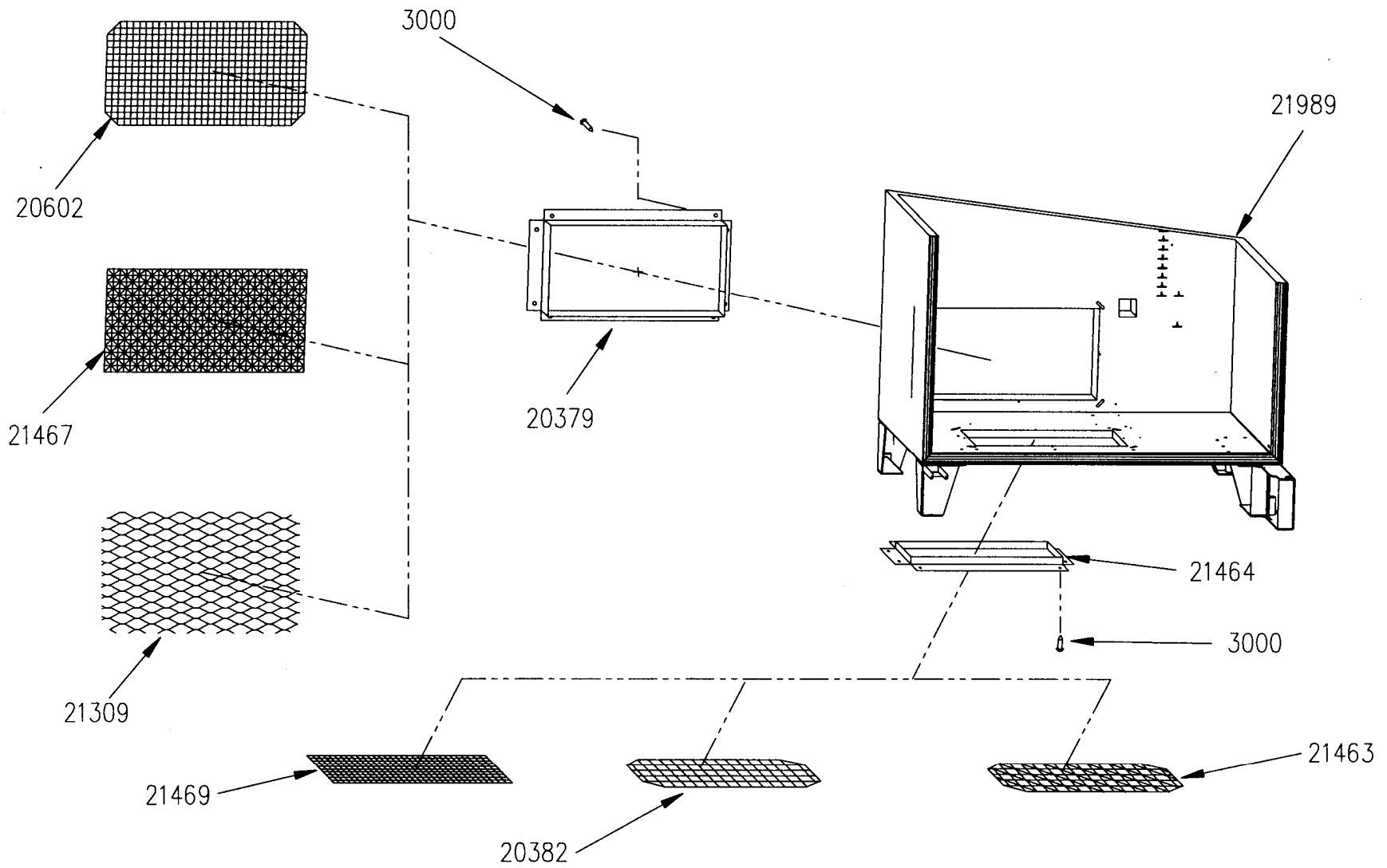

CABINET COVERS AND SCREENS PARTS LIST

PART NO.	PART NAME	QTY	NOTES
3000	Screw, Sheet Metal, TEK 8-18	8	Quantities For One Trim
20379	Trim, Rear Chiller Hole (35") (Black)	1	Use Screws
20382	Screen, Bottom Chiller Hole (35"), ¼ x ¼, Welded Galv. .025 Wire	1	
20602	Screen, Rear, Insect (35") Aluminum 18x16 Mesh	1	
21309	Screen, Expanded Metal, Rear Chiller Hole (35") ¾ 16 Gauge	1	16 GA. Flattened Galvanized Carbon Steel
21463	Screen, Bottom Chiller Hole, (35") 8 Mesh, VER 2	1	
21464	Trim, Bottom Chiller Hole (35") VER 2	1	Use Screws
21467	Screen, Rear Chiller Hole, 8 Mesh (35")	1	
21469	Screen, Bottom, Insect (35"), VER 2 Aluminum 18x16 Mesh	1	
21989	Cabinet Wrapper - Outside of Assembly, Cabinet, Low Temp (35")	1	
	Cabinet Tank - Inside of Assembly, Cabinet, Low Temp (35")		

General Note: The rear opening and the bottom opening are not the same size on 35" Cabinets. All screen materials are fitted into trim, and the trim then attached on the outside of the cabinet with screws. The combination of mesh and screens used may differ between merchandisers.

CABINET PARTS FOR VCB AND VCF ILLUSTRATION

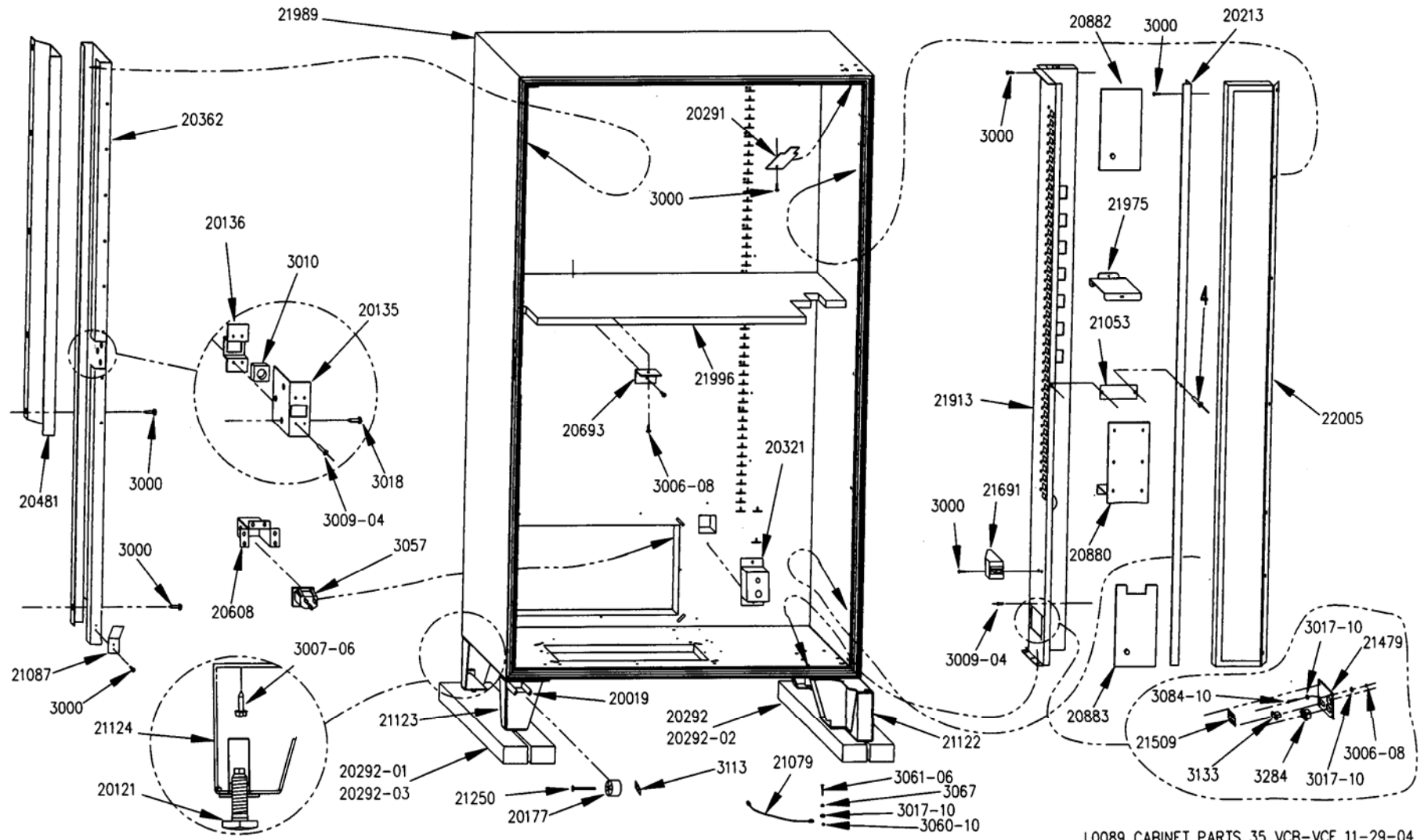

L0089 CABINET PARTS 35 VCB-VCF 11-29-04

CABINET PARTS FOR VCB AND VCF PARTS LIST

PART NO.	PART NAME	QTY	NOTES
3000	Sheet Metal Screw TEK #8-18	54	(Estimated Qty)
3006-08	Nut, 8-32, Hex, Machine Screw	1	For Attaching Power Harness
3007-06	Screw, 5/16-18, Type F	16	4 Per Leg
3009-04	Rivet, Pop, Steel, 1/8 x 1/4 Grip	10	For Lock (Est. Qty)
3010	Nut, Square, Machine Screw, 1/2"-13	1	For Lock
3017-10	Washer, #10 SAE Flat	4	For Power Harness and Door Stop Cable
3018	Sheet Metal Screw, 1/4"	3	For Lock
3057	Inlet, Panel Mount, IEC	1	Snapped Into Place at Rear of Cabinet
3060-10	Nut, 10-32, W/Nylon Insert	2	For Door Stop Cable
3061-06	Screw, 10-32 x 3/4 Phillips Pan Head	2	For Door Stop Cable
3067	Spacer, .192 ID x .125 Length x 3/8 Dia.	2	For Door Stop Cable
3084-10	Screw, Sems, 8-32	1	For Power Harness
3113	Push Nut, 3/16" Stud	2	
3133	Assembly, Fuse Holders and Fuses	1	For 3AG Fast Blow Fuse Only
3284	Switch, Rocker, On/Off	1	For 24VAC Circuit Control
20019	Leg, Roller Bracket	1	
20121	Leveling Leg	5	Cabinet To Be Leveled Using All Legs
20177	Roller, Molded (Nylon)	1	
20135	Lock Flange	1	For Lock
20136	Lock Cage	1	For Lock
20213	Flange, Right Vertical	1	
20292	Shipping Board	1	Right Side 40" Long
20292-2	Shipping Board	1	Right Side 38-3/8" Long
20292-01	Shipping Board	1	Left Side 40" Long
20292-03	Shipping Board	1	Left Side 38-3/8" Long
20291	Cover Plate, Hinge Hole, Ver. 2	1	For Top Hinge
20321	Cover, IEC Inlet	1	For Securing Cord Grommet
20362	Rail Mount, Left Vertical (3")	1	
20481	Extension, Left Vertical Rail Mount	1	
20608	Cover, Power Cord	1	Optional For Securing Power Cord
20693	1" Bracket	4	For Securing Visi-Combo Bulkhead
20880	Cover Plate, Transformer, Low Temp	1	

20882	Cover Plate, Fixed Upper, Low Temp	1	
20883	Cover Plate, Fixed Lower, Low Temp	1	
21053	Stiffener, Right Vertical Rail Mount	1	
21079	Cable Assembly, Door Stop, Modified	1	
21087	Plate, Door Switch Spring	1	
21122	Assembly, Leg, Front Hinge With Thread Cover	1	
21123	Assembly, Leg, Left Front with Thread Covers	1	
21124	Assembly Leg, Rear with Thread Covers	2	
21250	Shaft, Headed Roller (Zinc Plated)	1	
21479	Plate, Fuse Holder, Socket And Power Switch Mount	1	
21509	Decal, 24V Fuse, Ver. 2	1	
21691	Enclosure, Fan Switch, Ver. 2	1	Uses Normally Open Switch, P/N 3199
21913	Rail Mount, Right Vertical, Low Temp (35")	1	
21975	Bulkhead, Right Rail Mount, Low Temp (35")	1	
21989	Assembly, Cabinet, Low Temp (35")	1	
21996	Bulkhead, Visi Combo Cabinet, Lot Temp (35")	1	For Visi-Combo Option
22005	Assembly, Right Rail Mount Door	1	

THIS PAGE INTENTIONALLY LEFT BLANK

CHILLER PARTS ILLUSTRATION - SIDE VIEW

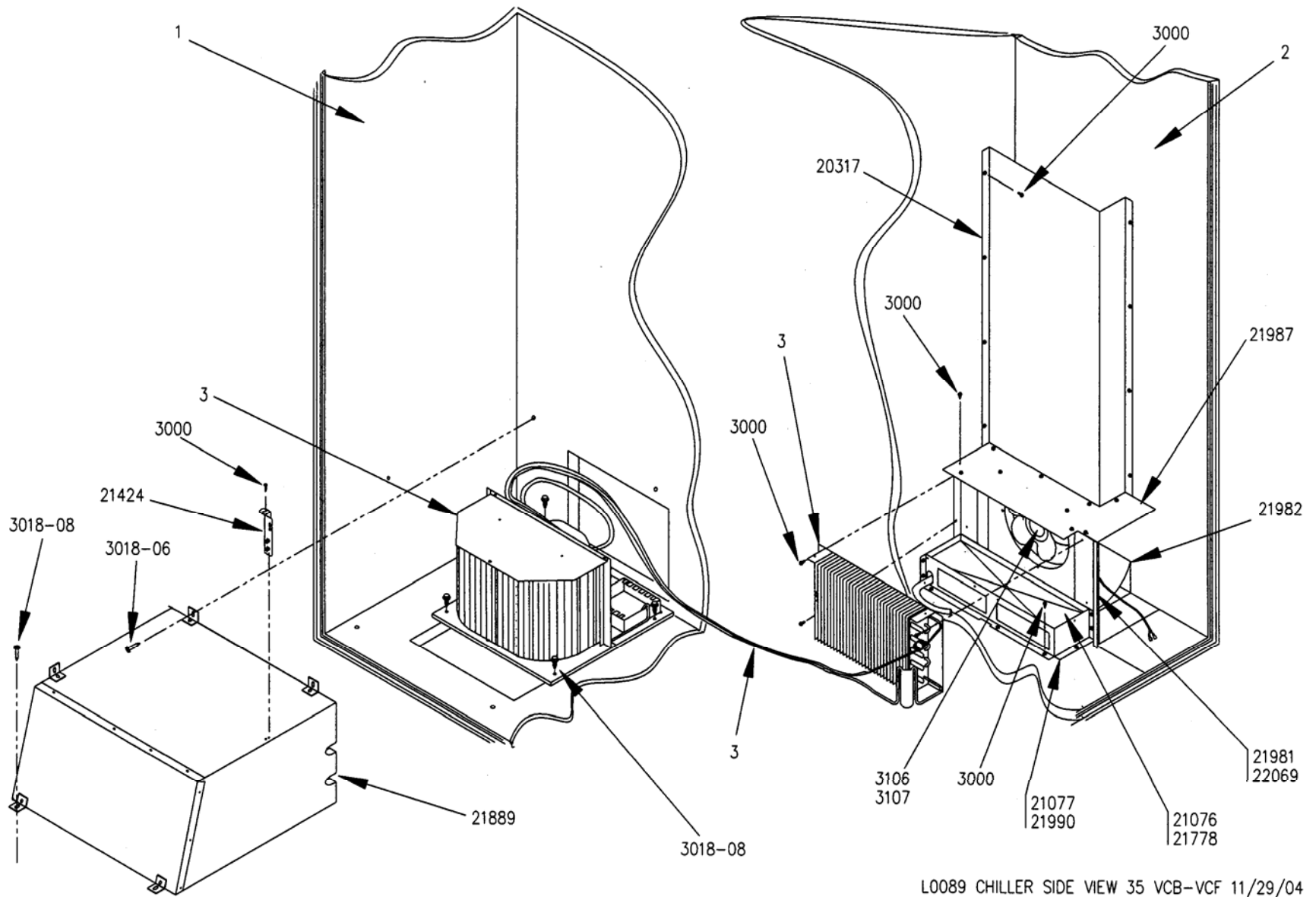

L0089 CHILLER SIDE VIEW 35 VCB-VCF 11/29/04

CHILLER PARTS LIST - SIDE VIEW			
PART NO	PART DESCRIPTION	QTY	NOTES (See Note A Below)
1	Cabinet Tank Wall, Left Side	---	For Reference
2	Cabinet Tank Wall, Right Side	---	For Reference
3	Chiller Unit (Condenser, Heat Exchanger, Evaporator)	1	For Reference, See Note A.
3000	Sheet Metal Screw TEK #8-18	46	(Estimated Qty)
3018-06	Screws, ¼ x ¾, Self Tapping, Hex Head	2	For Attaching To Walls
3018-08	Screws, ¼ x 1, Self Tapping, Hex Head	6	For Attaching To Floor
3106	Evaporator Fan/Motor Assembly, 220V, 50Hz, 1 Phase	1	Check Voltage!
3107	Evaporator Fan/Motor Assembly, 110V, 60Hz, 1 Phase		Check Voltage!
20317	Evaporator Plenum	1	Standard Plenum
21076	Pan, ½" Evaporator Drain	1	Soldered Pan
21077	Base, ½" Evaporator Drain Pan	1	For Use With 21076 Pan
21424	Bracket, Temperature Sensor, Sensit II	1	
21778	Pan, Evaporator Drain, Stamped Steel	1	Stamped Pan
21889	Housing, Chiller Housing, Low Temp (35"),	1	
21981	Evaporator Mounting Panel, Low Temp (35")	1	For Use With 21076 Pan
21982	Air Foil, Evaporator Fan, Low Temp (35")	1	
21987	Evaporator Cover Plate, Low Temp (35")	1	
21990	Base, Stamped, Evaporator Drain Pan	1	Use With 21778 Pan
22069	Evaporator Mounting Panel, Low Temp, Stamped Steel Drain Pan (35")	1	Use With 211778 Pan

NOTE A: Chiller assemblies are charged with refrigerant and are replaceable only as an assembly.

CHILLER PARTS ILLUSTRATION - TOP VIEW

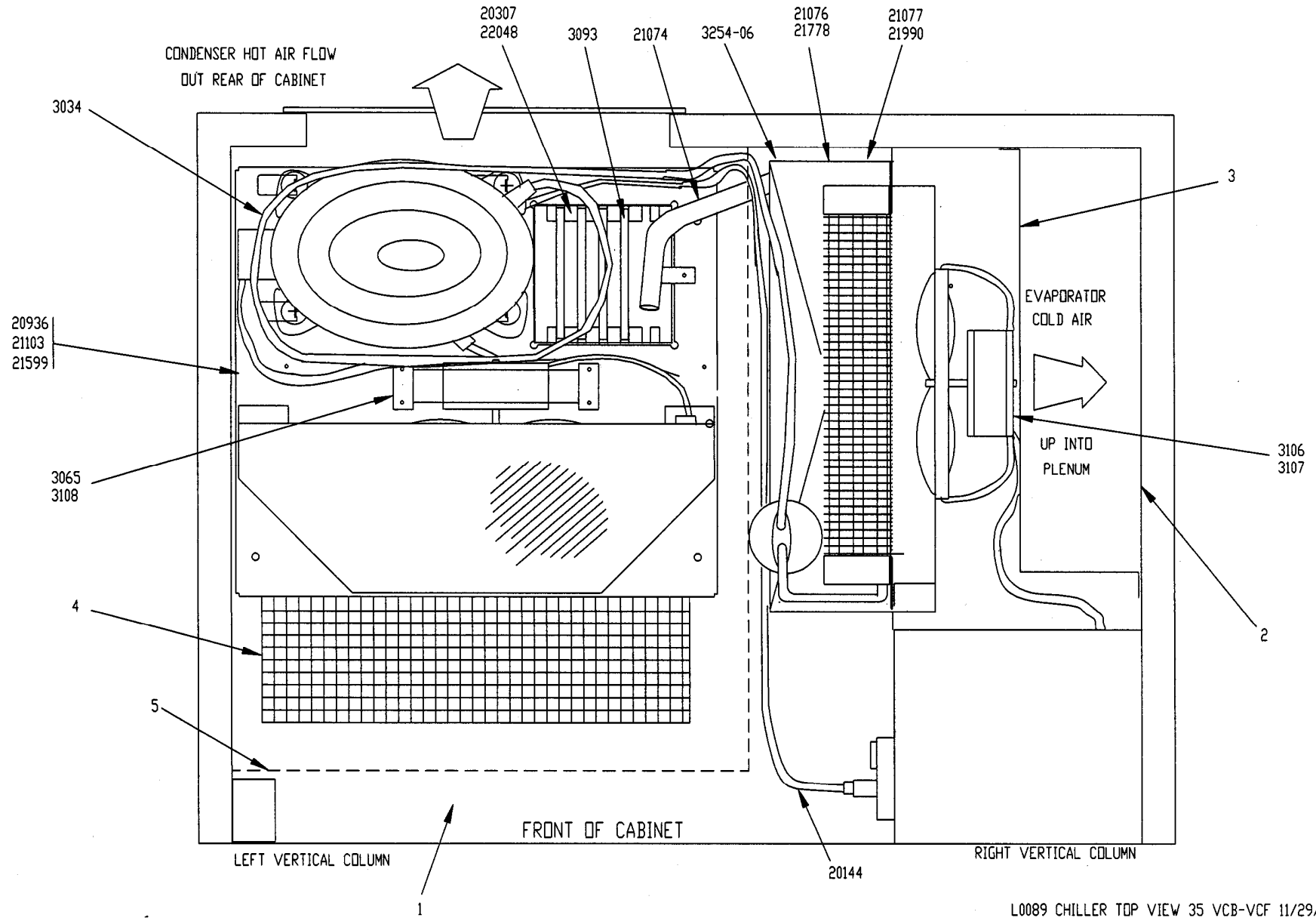

CHILLER PARTS LIST - TOP VIEW

PART NO	PART DESCRIPTION	QTY	NOTES (See Note A Below)
1	Cabinet Floor	1	For Reference
2	Inside Cabinet Wall, Right Side	1	For Reference
3	Cold Air Plenum Wall	1	For Reference
4	Condenser Air Inlet Screen Under Chiller	1	For Reference
5	Outline of Area Under Chiller Housing	1	For Reference
3034	Split Insulation Tubing	1	Heat Exchanger Tubing Insulation, 7 Foot
3065	Fan, Condenser Assembly, 220V, 50Hz, 1 Phase	1	Check Voltage!
3093	Sponge (Condenser Drain Pan)	4	
3106	Evaporator Fan/Motor Assembly, 220V, 50Hz, 1 Phase	1	Check Voltage!
3107	Evaporator Fan/Motor Assembly, 110V, 60Hz, 1 Phase	1	Check Voltage!
3108	Fan, Condenser Assembly, 110V, 60Hz, 1 Phase	1	Check Voltage!
3254-06	Tubing Clamp	1	Clamps Tube to Evaporator Pan Drain
20144	Refrigeration Harness	1	Use With Both 110V or 220V Systems
20307	Condenser Drain Pan	1	
20963	Assembly, 1/2 Plus H.P. Chiller, 120V (39"), AMS (WV)	1	Assembly Only
21074	Tubing, Clear Flexible Vinyl, 17"	1	Drains Evaporator Condensate
21076	Pan, 1/2" Evaporator Drain	1	Use With 21076 Pan
21077	Base, 1/2" Evaporator Drain Pan	1	Use With 21076 Pan
21103	Assembly, 1/2 Plus H.P. Chiller, 240V (39"), AMS (WV)	1	Assembly Only
21599	Assembly, 1/2 Plus H.P. Chiller, 120V (39"), AMSINT (MEX)	1	Assembly Only
21778	Pan, Evaporator Drain, Stamped Steel	1	Use With 21778 Pan
21990	Base, Stamped, Evaporator Drain Pan	1	Use with 21778 Pan
22048	Condenser Drain Pan, Formed	1	

NOTE A: Chiller assemblies are charged with refrigerant and are replaceable only as an assembly.

DOOR COIN BAY ILLUSTRATION

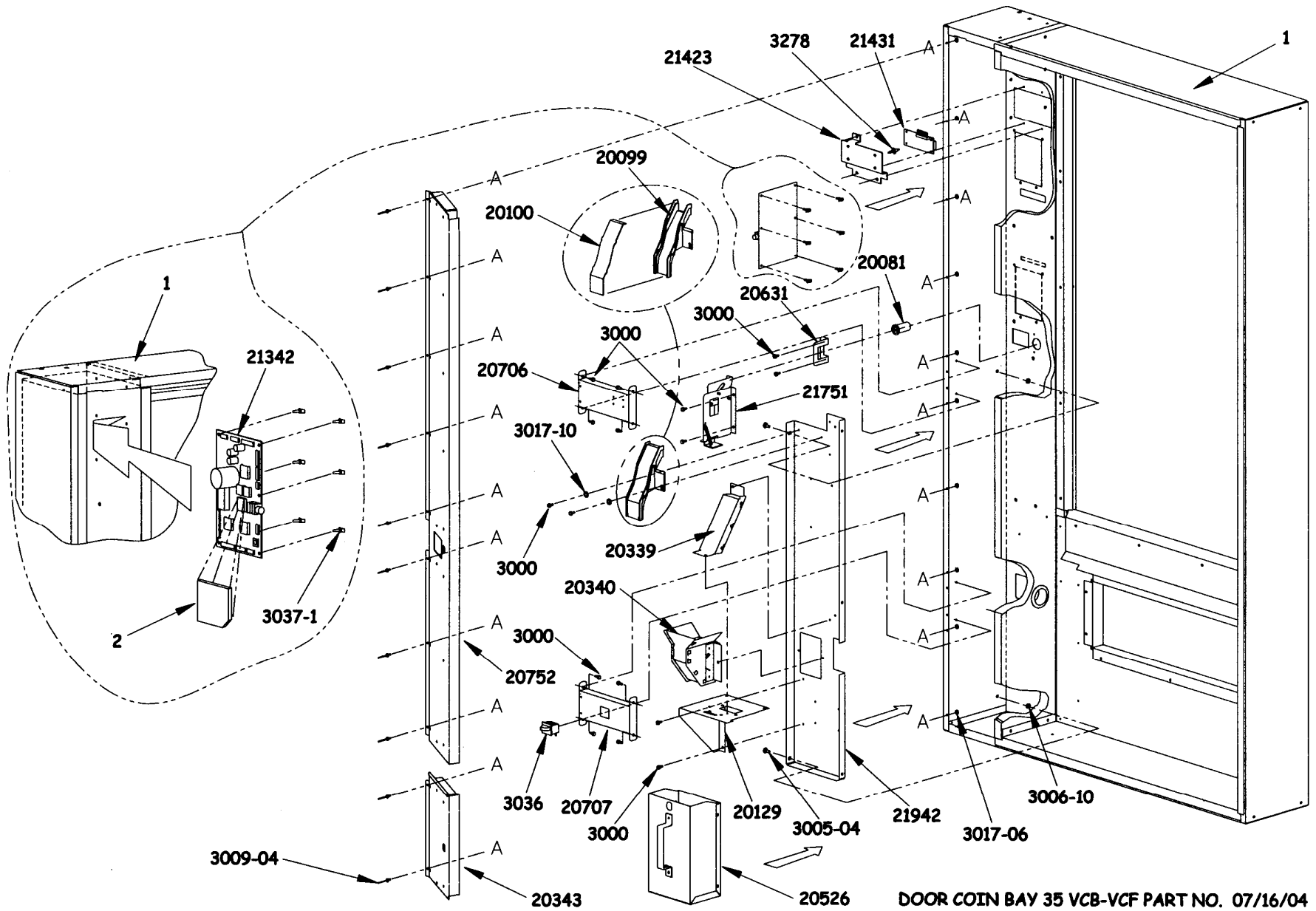

DOOR COIN BAY PARTS LIST

PART NO.	PART NAME	QTY	NOTE
----	Assembly, Foamed Door, 35"	1	See Door External Parts for P/N
---	Program Chip	1	Contact AMS for your application.
3000	Screw, Sheet Metal TEK 8-18	18	
3005-04	Carriage Bolt, #10-24, 1/2"	5	
3006-10	Nut, Hex, Machine Screw, #10-24	5	
3009-04	Rivet, Steel, 1/8", Black, 3/8"-Grip Length 1/4"	10	
3017-06	Washer, Flat Steel, SAE Std., #6 Screw 5/32	10	
3017-10	Washer, Flat Steel, SAE Std., #10 Screw 7/32 X 1/2	2	
3036	Switch, Panel Mount Rocker	1	
3037-1	PC Board Support (3/16")	6	
3038	Rivet, Nylon, Trim	5	
3278	Circuit Board Support	4	Sensit II
20081	Scavenger Button	1	
20099	Coin Chute, Insert	1	
20100	Coin Chute Cover	1	
20129	Coin Box Bulkhead	1	
20339	Assembly, Coin Chute	1	
20340	Assembly, Coin Cup	1	
20343	Coin Door Assembly, Lower	1	
20526	Assembly, Coin Box	1	
20631	Bracket, Scavenger Stop	1	
20706	Door Stiffener, Upper, Without Fuse And Switch	1	
20707	Door Stiffener, Bottom With Switch	1	
20751	Assembly, Scavenger	1	
20752	Assembly, Coin Door, Upper (51")	1	
21342	Control Board, Sensit II	1	Sensit II
21423	Bracket, Display 80mm x 36mm	1	Sensit II
21431	Display, 2 Line, 16 Character, Sensit II	1	Sensit II
21942	Mounting Panel, Changer, Multi-Use	1	

DOOR, EXTERNAL PARTS ILLUSTRATION

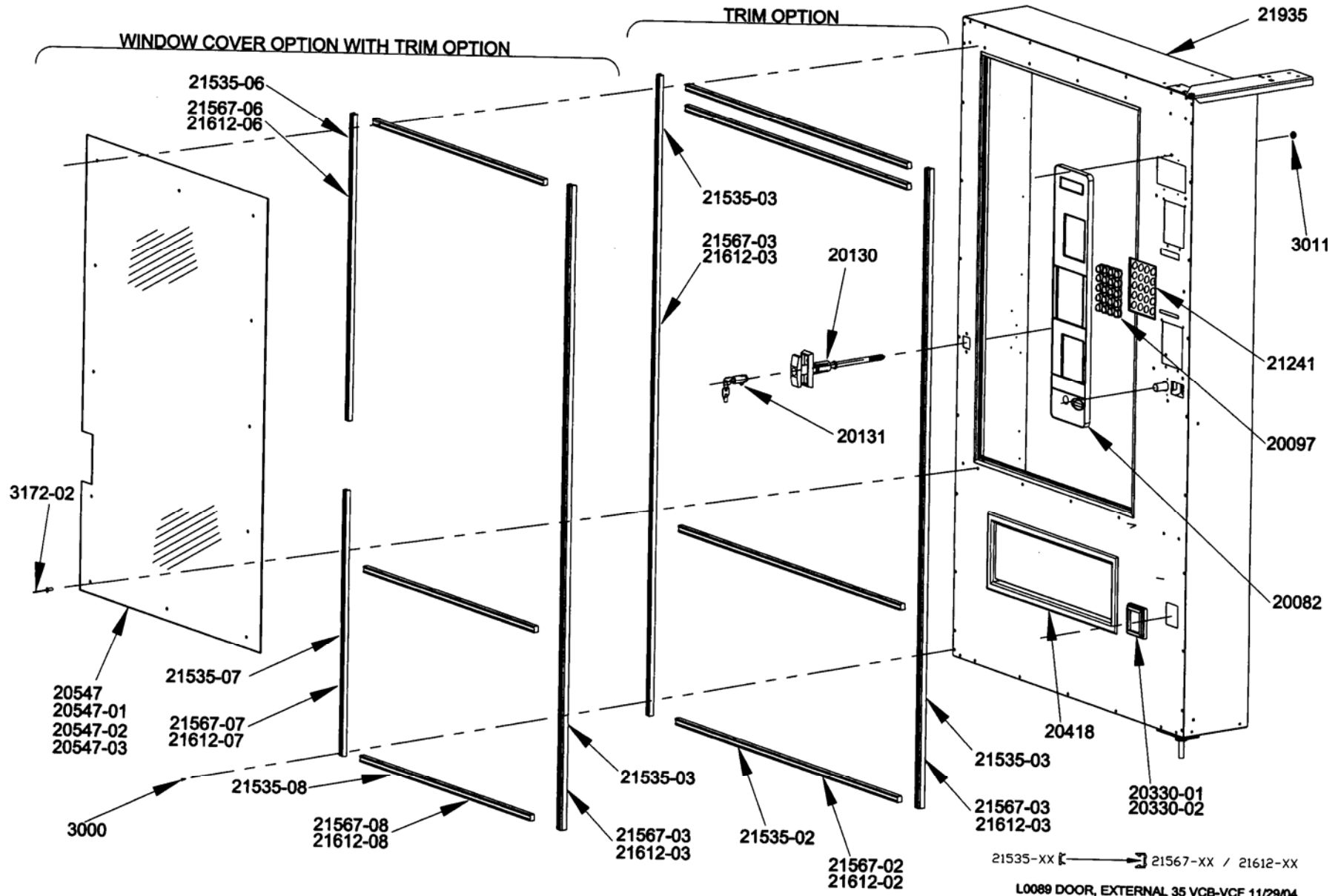

DOOR, EXTERNAL PARTS LIST

PART NO.	PART NAME	QTY.	NOTE
3000	Screw, Sheet metal, TEK 8-18	28	For Securing Trim (Est. Qty)
3011	Self Threading Nut, ¼" Stud	8	For Securing Escutcheon
3172-02	Rivet, Aluminum, ¼" Diameter, Natural (1/4" Grip)	15	For Securing Window Covers
20082	Escutcheon	1	
20097	Button	20	
20130	T-Lock Assembly (Lockset And Keys 20131)	1	
20131	Lockset And Keys	1	
20330	Trim, Extruded Edge (20330-01 and -02)	2	
20418	Assembly, Vend Eyelet (35")	1	
20547	Window Cover, Polycarbonate (39"), .110 Thick	1	See Note A
20547-01	Window Cover, Polycarbonate (39"), .180 Thick		
20547-02	Window Cover, Polycarbonate (39"), .234 Thick		
20547-03	Window Cover, Polycarbonate (39"), .234 Thick, MR-10 Scratch Resistant		
21241	Assembly, Membrane Switch, Alpha-Numeric	1	
21535-02	Trim, Plastic Insert, For Recessed Base (31.9")	4	See Note A – Snaps into Base
21535-03	Trim, Plastic Insert, For Recessed Base (65.1")	1	Snaps into Base
21535-06	Trim, Plastic Insert, For Recessed Base (30.2")	1	Snaps into Window Cover Base
21535-07	Trim, Plastic Insert, For Recessed Base (29.4")	1	Snaps into Window Cover Base
21535-08	Trim, Plastic Insert, For Recessed Base (23.9")	3	Snaps into Window Cover Base
21567-02	Recessed Trim Base With Holes	4	See Note A - Aluminum Finish
21567-03	Recessed Trim Base With Holes	1	Aluminum Finish
21567-06	Recessed Trim Base With Holes	1	Aluminum Finish Window Cover Base
21567-07	Recessed Trim Base With Holes	1	Aluminum Finish Window Cover Base
21567-08	Recessed Trim Base With Holes	3	Aluminum Finish Window Cover Base
21612-02	Recessed Trim Base With Holes, Painted	4	See Note A - Black Paint
21612-03	Recessed Trim Base With Holes, Painted	1	Black Paint

21612-06	Recessed Trim Base With Holes, Painted	1	Black Painted Window Cover Base
21612-07	Recessed Trim Base With Holes, Painted	1	Black Painted Window Cover Base
21612-08	Recessed Trim Base With Holes, Painted	3	Black Painted Window Cover Base
21935	Assembly, Door, Low Temp, Steel Doubler w/Trim Only (35")	1	Door P/N For Trim Only / No Window Cover .

Note A: Trim Packages, Window Cover Packages and other options contracted for and installed at AMS may not apply to your vendor.

THIS PAGE INTENTIONALLY LEFT BLANK

DOOR HINGES AND GLASS ILLUSTRATION

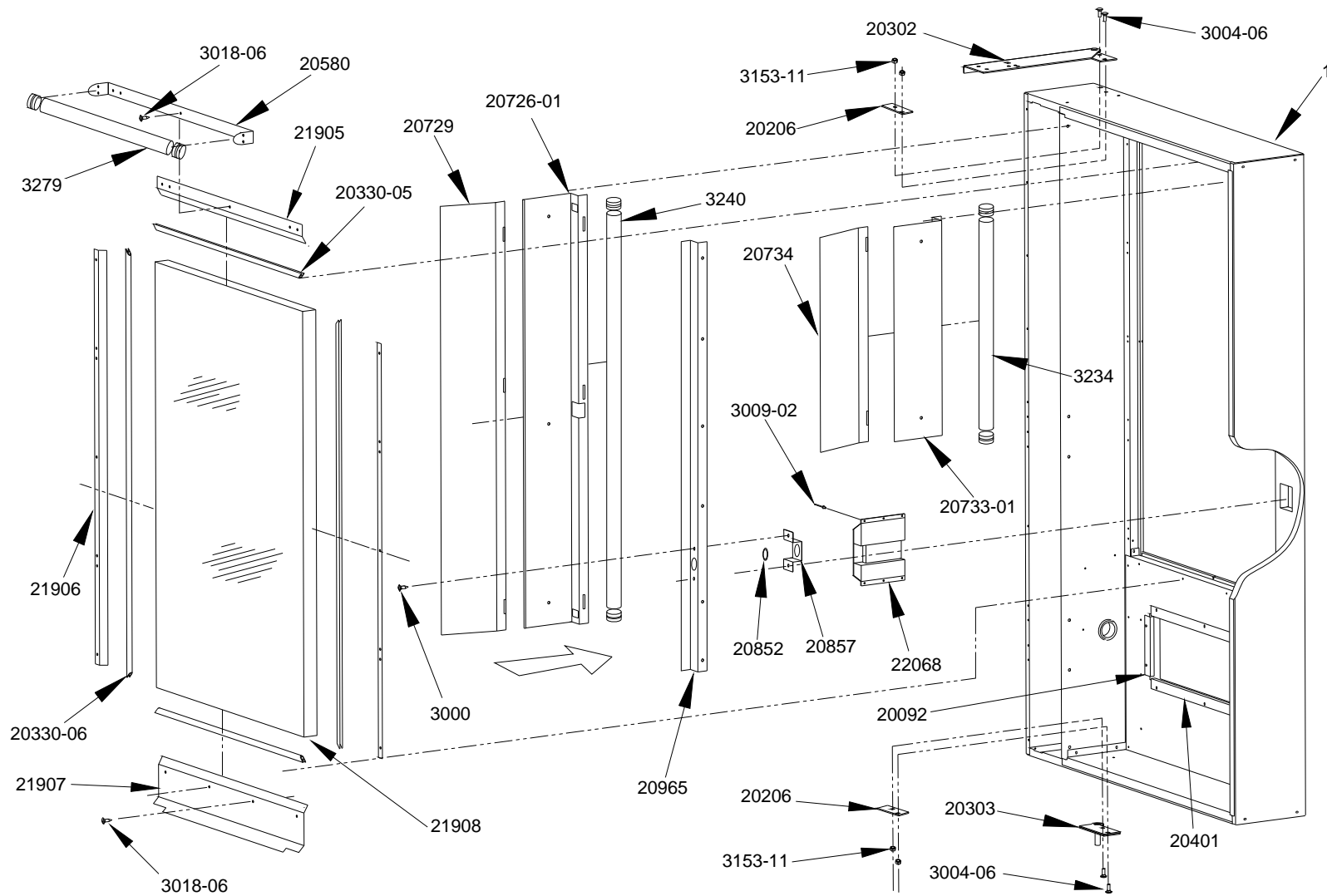

DOOR HINGES-GLASS 35 VCB-VCF Part No. 07/16/2004

DOOR HINGES AND GLASS PARTS LIST

PART NO.	PART DESCRIPTION	QTY.	NOTE
----	Assembly, Foamed Door 35"	1	See Door External Parts For Door P/N's
3000	Screw, TEK 8-18	9	
3009-02	Rivet, Pop, Steel, 1/8 Diameter	6	
3018-06	Screw, ¼ X ¾, Self Tapping, Hex Head	20	For Glass Retainers
3004-06	Carriage Bolt, ¼-20, ¾"	4	
3153-11	Nut, Hex With Lock Washer	4	
3234	Lamp Cover, T8, 24", Clear, With End Caps	1	VCF Option
3240	Lamp Cover, T8, 36", Clear, With End Caps	1	VCF Option
3279	Lamp Cover, T8, 18", Clear, With End Caps	1	VCB Option Make by Cutting 3240 in Half
20092	Retainer, Vert. Eyelet (35")	2	
20206	Hinge, Washer Plate	2	
20302	Assembly, Hinge, Top (Black), Door	1	
20303	Assembly, Hinge Bottom, Door	1	
20401	Retainer, Hor. Eyelet (35")	2	
20330-05	Trim, Extruded Edge, 21.32 (Required for Glass), Hor.	2	Use with Glass
20330-06	Trim, Extruded Edge, 41.00 (Required For Glass), Vert.	2	Use with Glass
20726-01	Lamp Bracket, 36" Vertical	1	For VCF Dual Light Option
20729	Lamp Cover, 36" Vertical	1	Clear Polycarbonate
20733-01	Lamp Bracket, 24" Vertical	1	For VCF Dual Light Option
20734	Lamp Cover, 24" Vertical	1	Clear Polycarbonate
20852	Seal, T-Handle, Low Temp	1	
20857	Lock Bolt Alignment Bracket	1	
20965	Tray Restraint, Low Temp, Reduced Depth	1	
21905	Retainer, 1-1/8" Triple Pane Glass, Top, Low Temp (35")	1	
21906	Retainer, 1-1/8" Triple Pane Glass, Vertical, Low Temp (35")	2	
21907	Retainer, 1-1/8" Triple Pane Glass, Bottom With Deflector, Low Temp (35")	1	
21908	Window, Glass, 1-1/8" Triple Pane, Low Temp (35")	1	
21910	Lamp Bracket, Horizontal, Low Temp (35")	1	For VCB Option
22068	Assembly, Lock Bolt Cover, Low Temp, Ver. E.	1	

DOOR, HOPPER WITH SENSIT II ILLUSTRATED

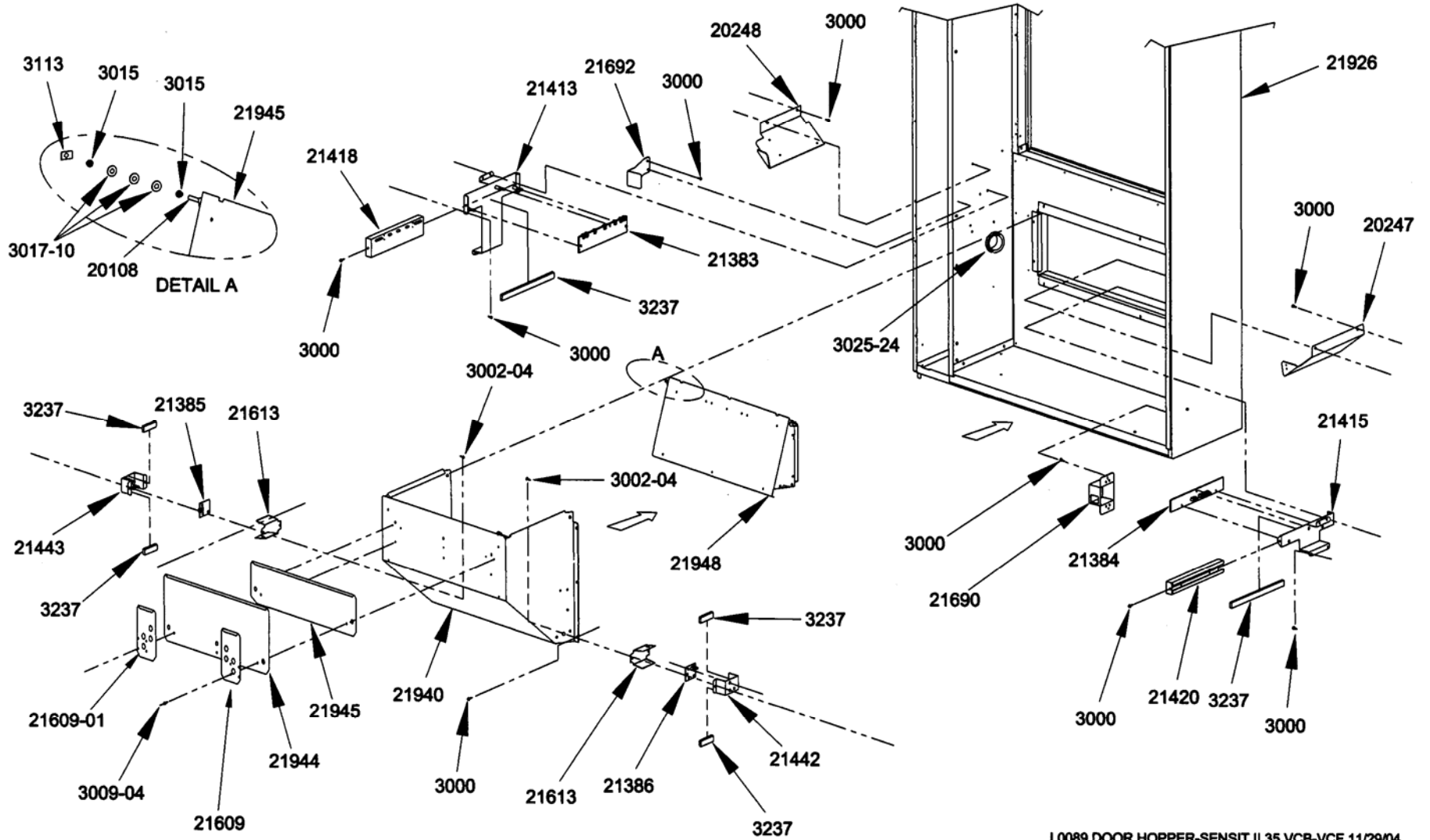

L0089 DOOR HOPPER-SENSIT II 35 VCB-VCF 11/29/04

DOOR, HOPPER WITH SENSIT II PARTS LIST

PART NO.	PART DESCRIPTION	QTY.	NOTE
3000	Screw, TEK 8-18	28	(Estimated Quantity)
3002-04	Screw, Machine, Type F, 8-32	4	¾" Long, Self-Tap, Phillips, Round Head
3009-04	Rivet, Pop, Steel, 1/8 x 1/4 Grip	8	(Estimated Quantity)
3015	Bearing, Nyliner Snap-In	4	
3017-10	Washer, Flat Steel, SAE Std. , #10 Screw 7/32 X ½	6	
3025-24	Grommet, Rubber, 1-1/2 ID x (1-3/4 OD X .062 Groove)	1	Harness Pass-Through
3113	Pushnut, 3/16" Stud	2	
3237	Tape, 3/8 x ¼", Urethane Foam, Adhesive Backed	15"	Cut To Length As Required
20108	Vend Door, Shaft (39")	1	
20247	Product Kicker, Left	1	(Left Hand When Facing Front Of Door)
20248	Product Kicker Right	1	
20429	Deflector Plate, Gum and Mint, Right	1	Riveted to Hopper
20429-01	Deflector Plate, Gum and Mint, Right	1	Riveted to Hopper
21383	Detector, Delivery Sensor, Sensit II	1	
21384	Emitter, Delivery Sensor, Sensit II	1	
21385	Detector, Product Sensor, Sensit II	1	
21386	Emitter, Product Sensor, Sensit II	1	
21413	Assembly, Delivery Sensor Detector Bracket, Sensit II	1	
21415	Assembly, Delivery Sensor Emitter Bracket, Sensit II	1	
21418	Assembly, Delivery Sensor Detector Cover, Sensit II	1	
21420	Assembly, Delivery Sensor Emitter Cover, Sensit II	1	
21442	Assembly, Product Sensor Emitter Bracket, Sensit II	1	
21443	Assembly, Product Sensor Detector Bracket, Sensit II	1	
21609	Deflector, 1.5" Helix Tray, RH	1	Riveted to Back Of Hopper (Top Bent Back 45°)
21609-01	Deflector, 1.5" Helix Tray, LH	1	Riveted to Back Of Hopper (Top Bent Back 45°)
21613	Lens, Product Sensor Bracket, Sensit II	2	
21690	Enclosure, Door Switch, Ver 2	1	Uses Normally Closed Switch, P/N 3036
21692	Plate, Fan Switch Striker, Ver. 2	1	Above Detector Sensor
21926	Assembly, Foamed Door, Steel Doubler, Low Temp (35")	1	
21940	Assembly, Vend Hopper, Low Temp (35")	1	
21944	Deflector Plate, Reduced Depth, Low Temp (35")	1	Riveted to back of Hopper
21945	Deflector Plate, 1-3/4 Height, Low Temp (35")		
21948	Assembly, Vend Door, Low Temp (35")	1	

POS DISPLAY ILLUSTRATION

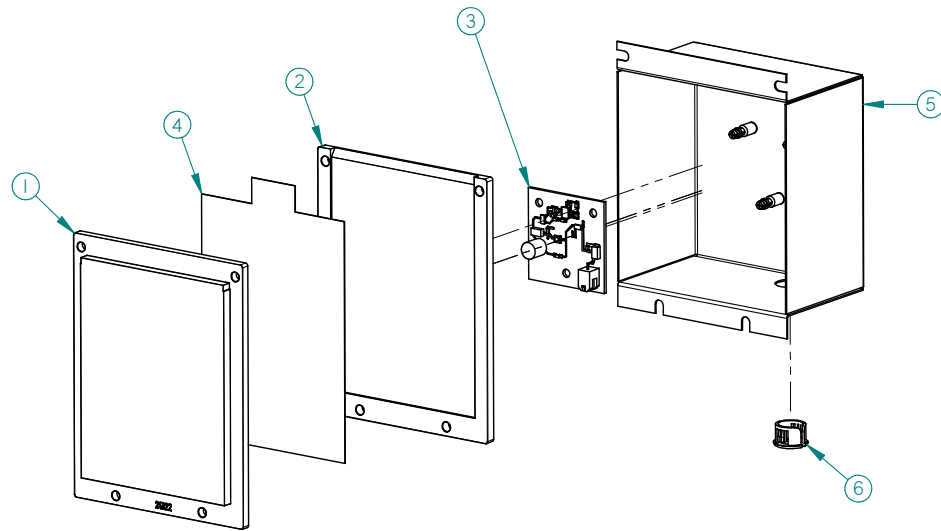

POS DISPLAY PARTS LIST			
ITEM	PART NO.	PART DESCRIPTION	NOTE
1	24322	POS DISPLAY INSERT	
2	24323	POS DISPLAY DIFFUSER	
3	24329	LED BOARD	
4	24330	POS DISPLAY CARD (AMS)	ENGLISH
	24457	POS DISPLAY CARD (IAMS)	SPANISH
5	24339	LIGHT BOX ASSEMBLY	
6	3029-02	BUSHING	

ELECTRICAL HARNESS ILLUSTRATIONS

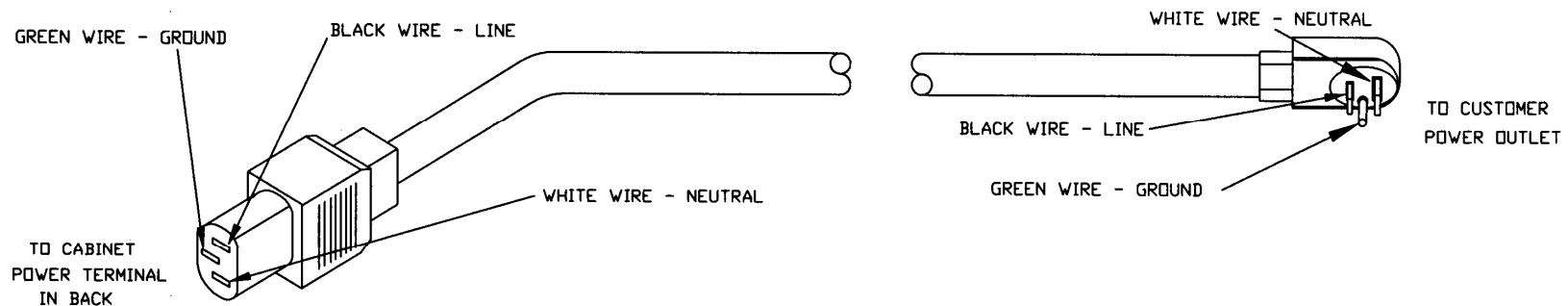

20142, POWER CORD ASSEMBLY, 115V DOMESTIC (U.S.)

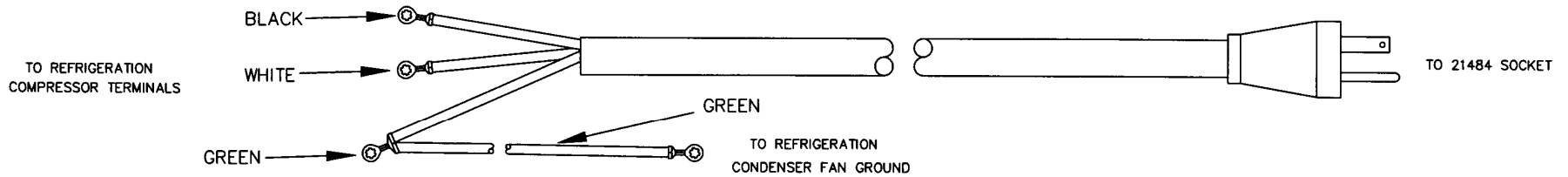

20144, HARNESS, REFRIGERATION

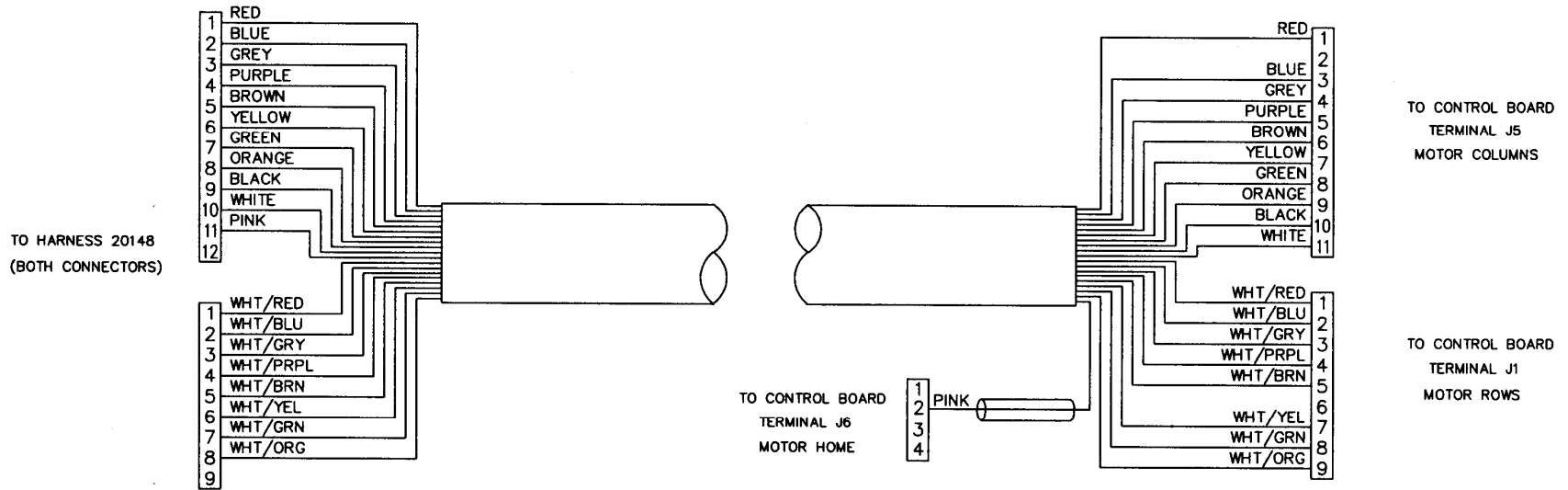

20146, HARNESS, DOOR MOTORS

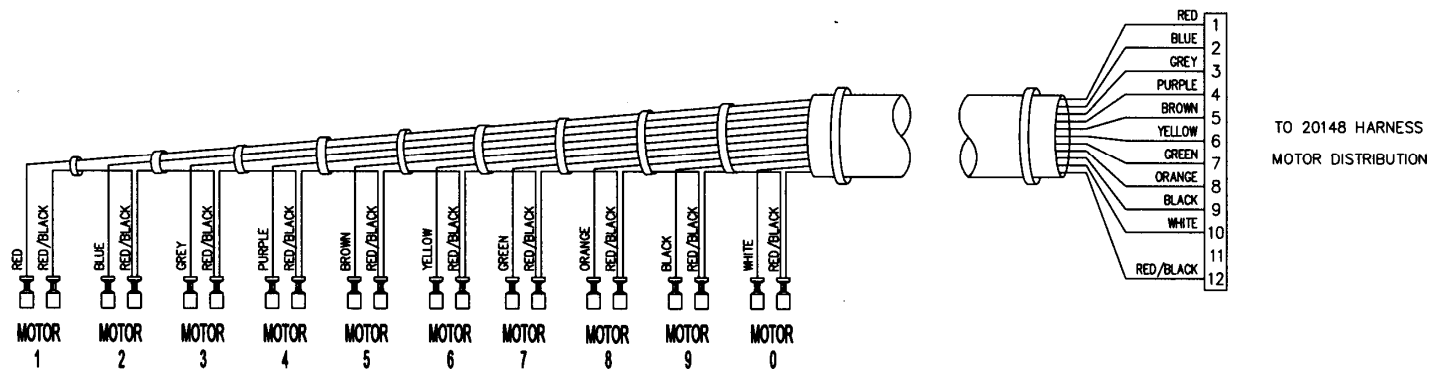

20147, HARNESS, TRAY, 10 COLUMN

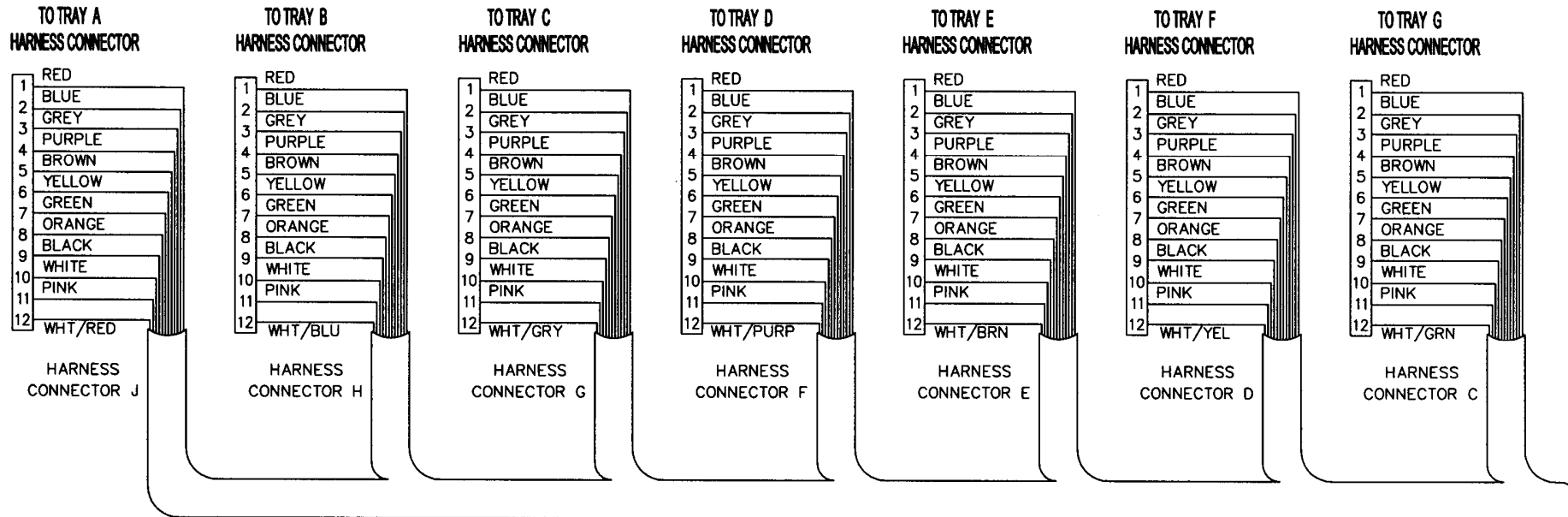

(CONNECTOR A IS JUMPERED TO ALL CONNECTORS TO TRAYS, PINS 1 -11)

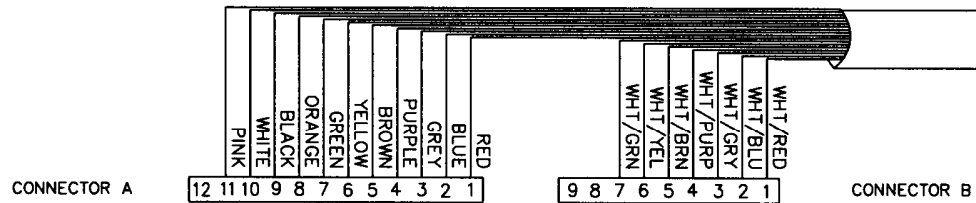

CONNECTOR A AND B TO 20146 HARNESS, DOOR MOTOR

20148, HARNESS, MOTOR DISTRIBUTION

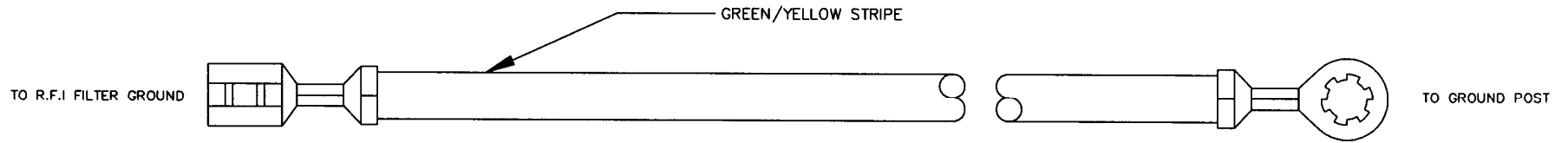

20154, HARNESS, R.F.I. FILTER GROUND

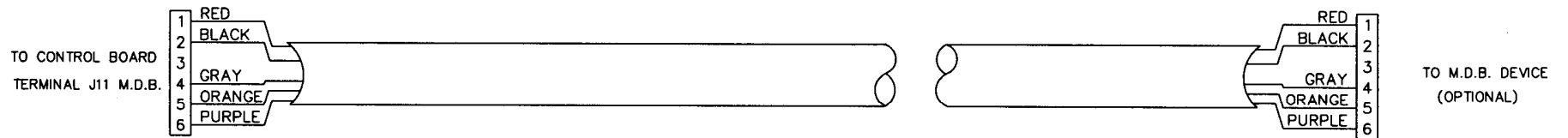

20158, HARNESS, MULTI-DROP BUS

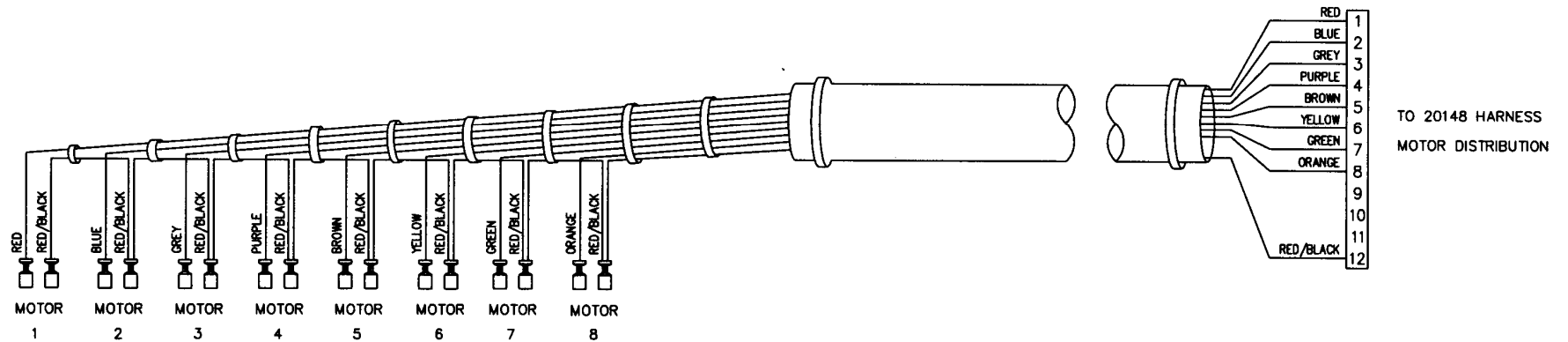

20163, HARNESS, TRAY, 8 COLUMN

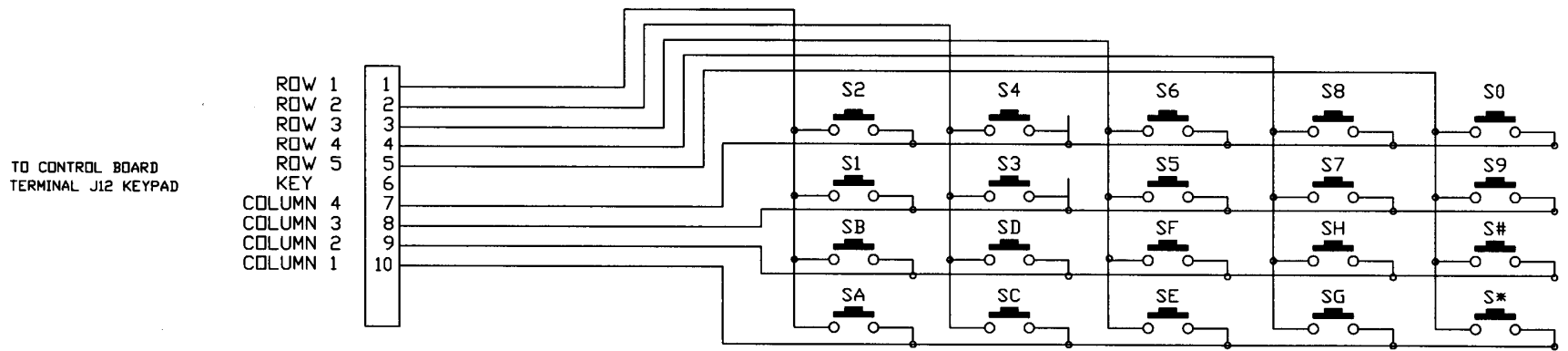

20199, MEMBRANE SWITCH, 4 X 5
 (HARNESS IS INTEGRAL WITH SWITCH)

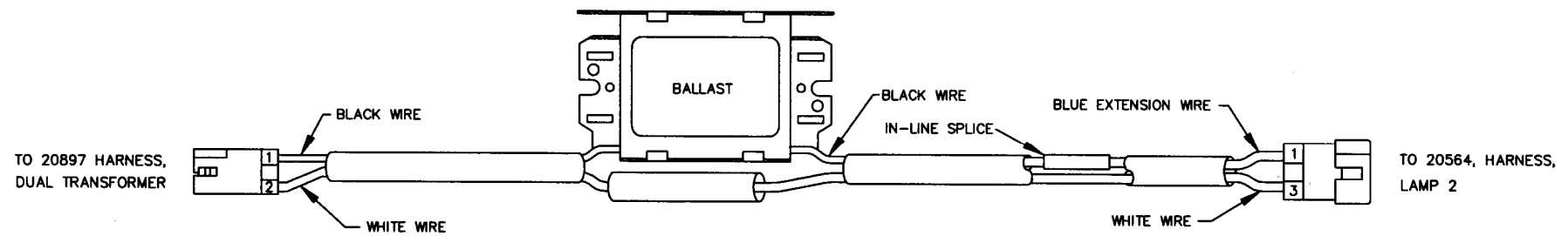

20563, HARNESS, BALLAST ASSEMBLY 2

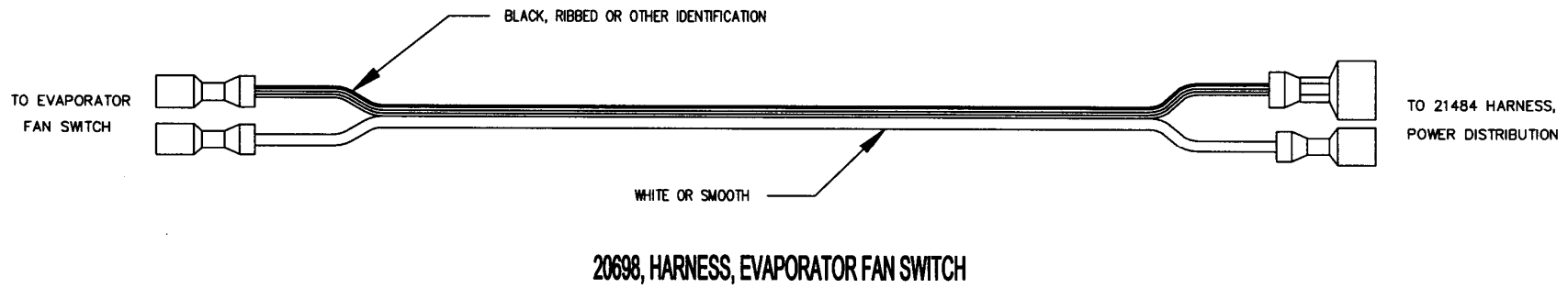
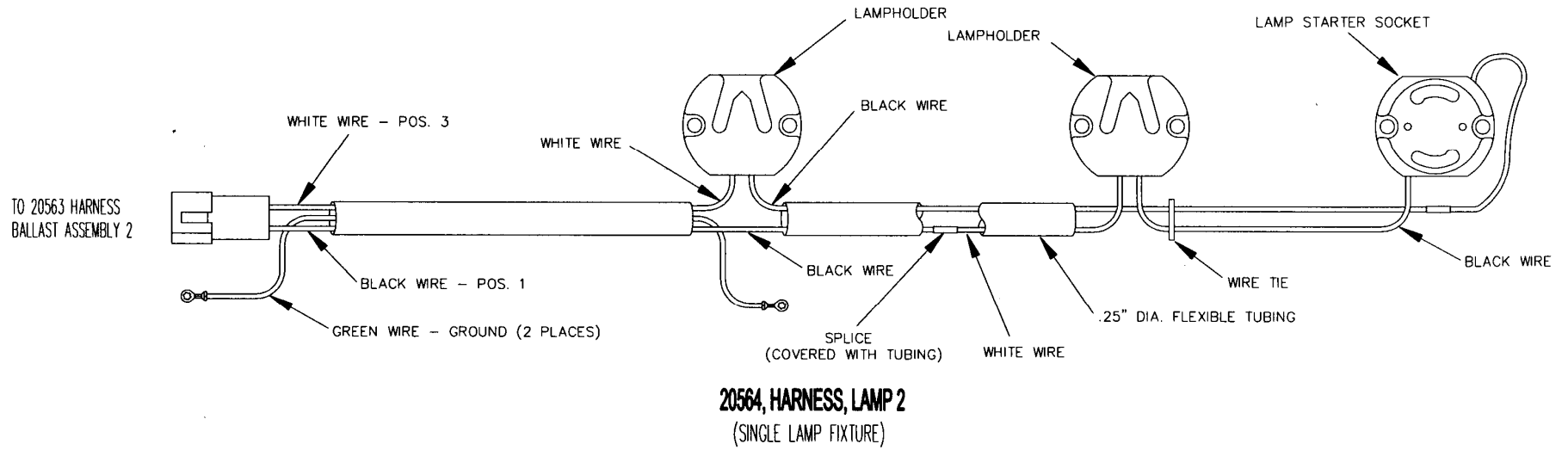

TO 21591 HARNESS, POWER
AND REFRIGERATION RELAY,
LEFT SIDE DOOR SWITCH

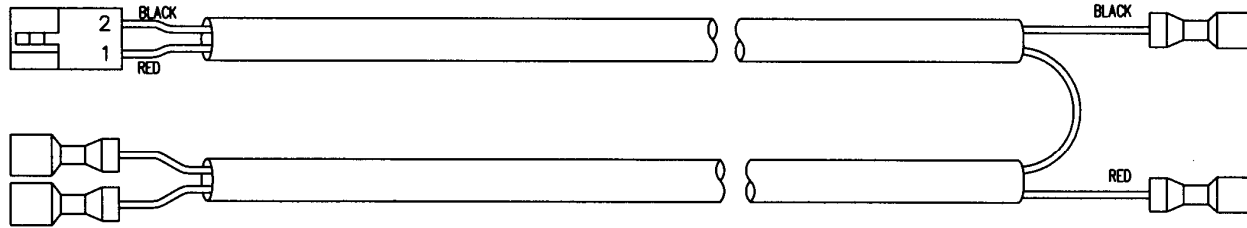

TO TRANSFORMER
24 VAC SECONDARY

20701, HARNESS, TRANSFORMER AND FUSE

TO 20730, HARNESS
BALLAST, DUAL LAMP

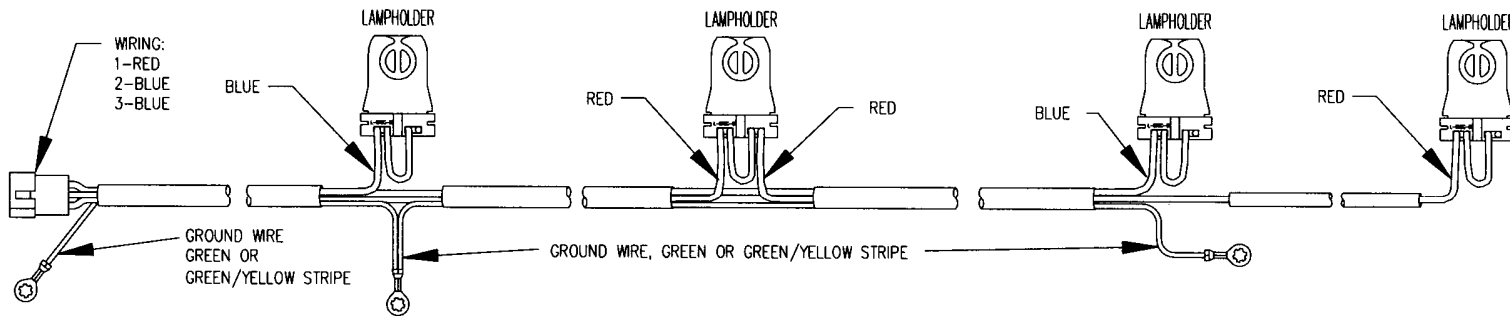

20718, HARNESS, DUAL LAMP 110V

TO 20897 HARNESS,
DUAL TRANSFORMER

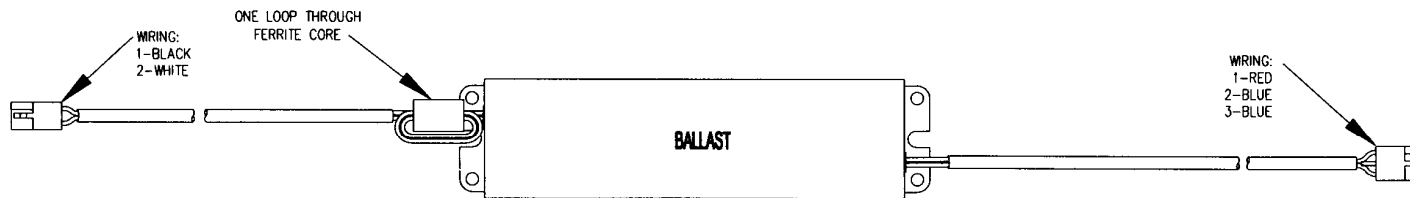

TO 20718, HARNESS,
DUAL LAMP

20730, HARNESS, BALLAST, DUAL LAMP 110V

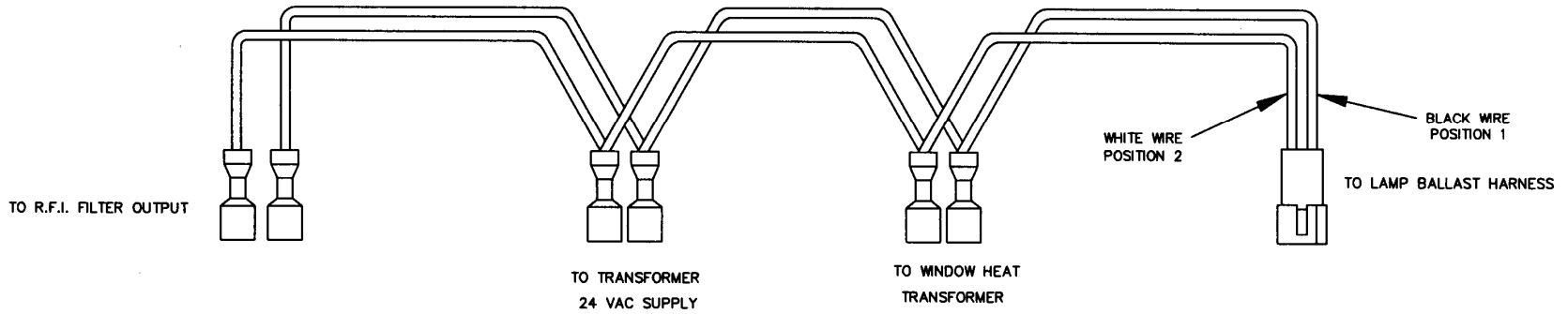

20897, HARNESS, DUAL TRANSFORMER

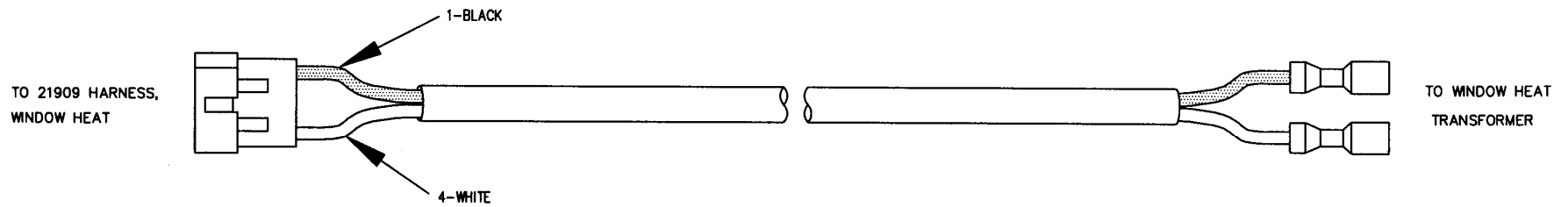

20899, HARNESS, WINDOW HEATER TRANSFORMER

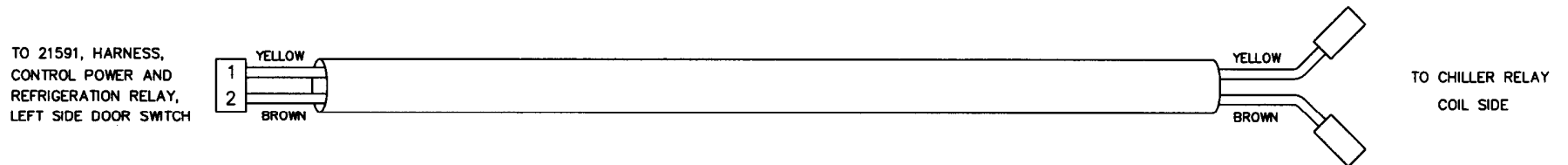

21405, HARNESS, REFRIGERATION RELAY, T9A SERIES

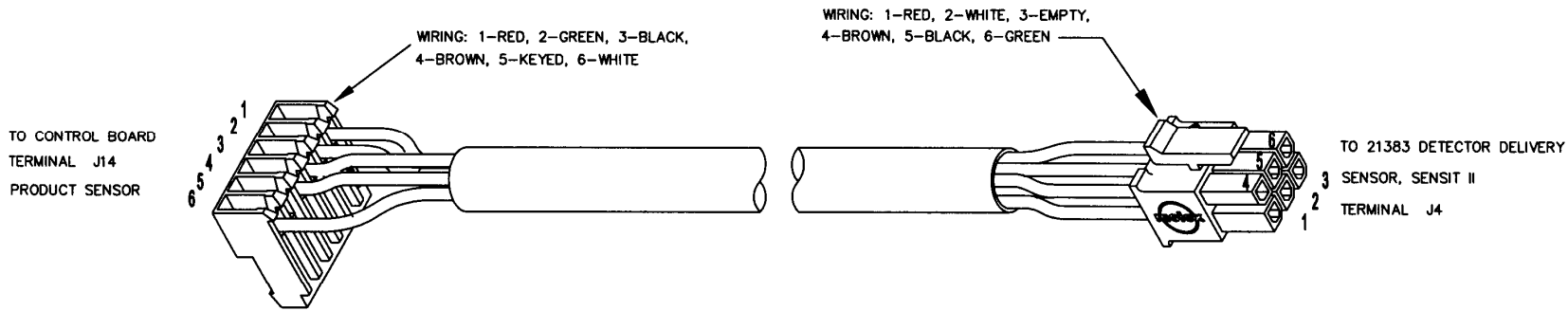

21425 HARNESS, DELIVERY SENSOR DETECTOR/CONTROL, SENSIT II

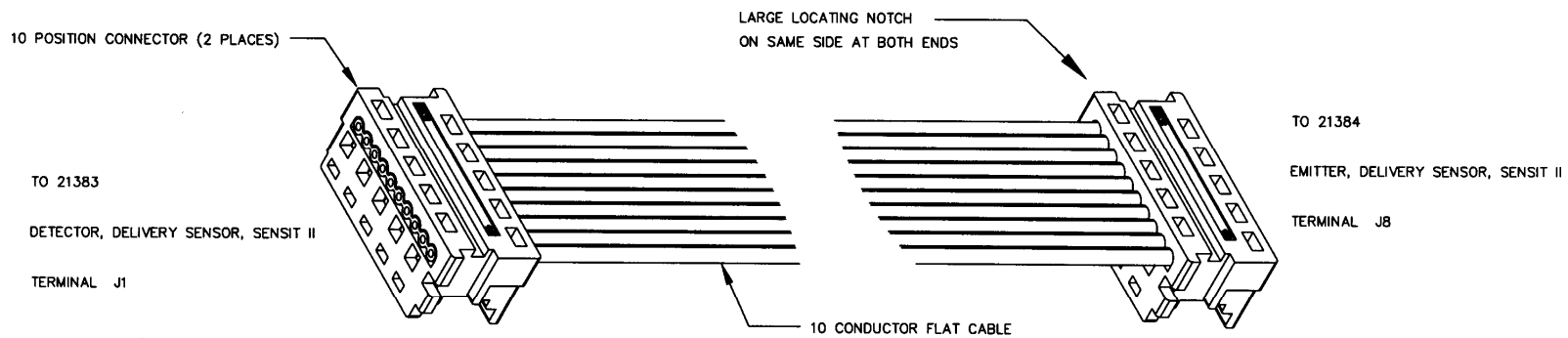

21426 HARNESS, DELIVERY SENSOR DETECTOR/EMITTER, SENSIT II

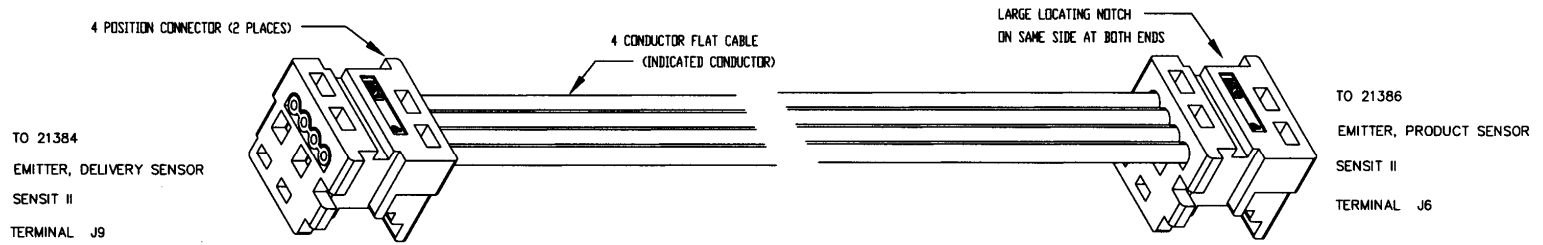

21427 HARNESS, PRODUCT SENSOR EMITTER, SENSIT II (OPTIONAL)

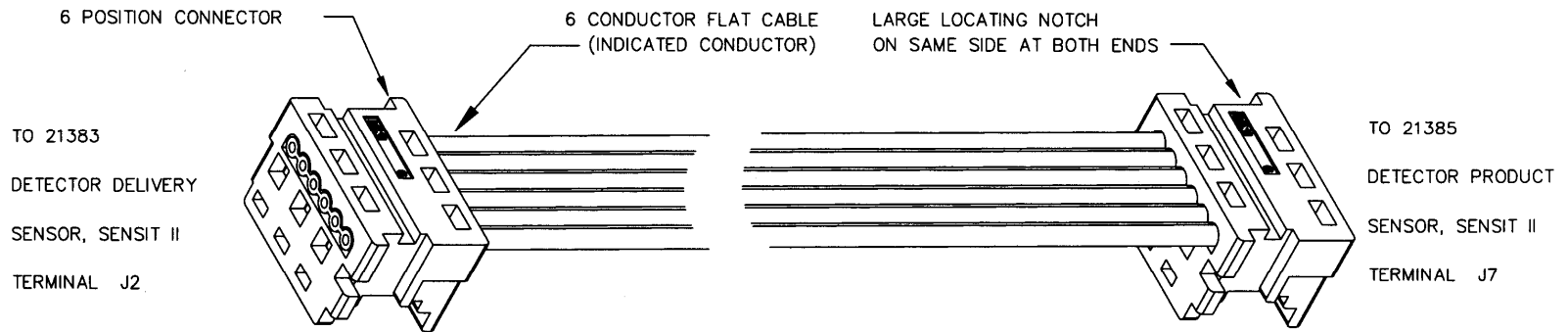

21428, HARNESS, PRODUCT SENSOR DETECTOR, SENSIT II (OPTIONAL)

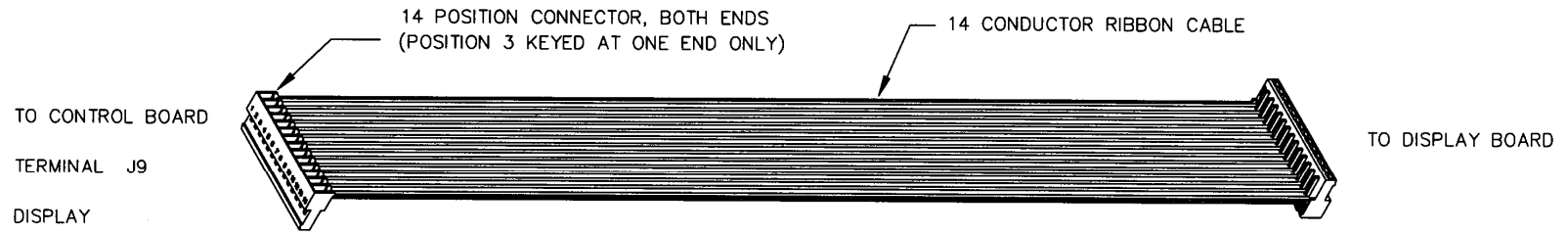

21432 HARNESS, DISPLAY, SENSIT II

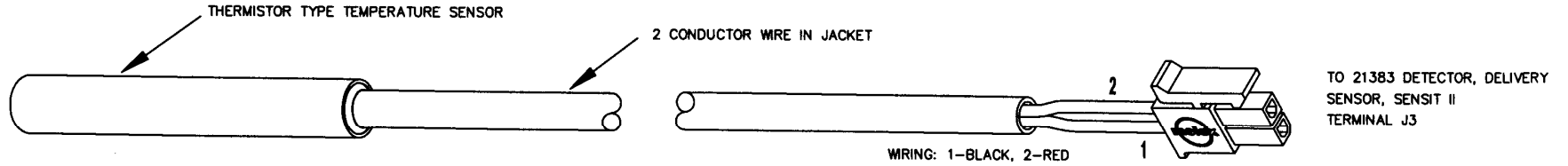

21468 TEMPERATURE SENSOR, SENSIT II

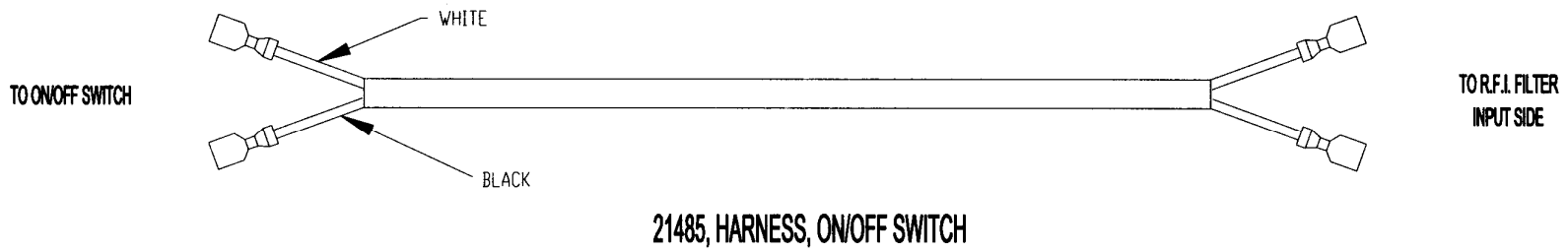
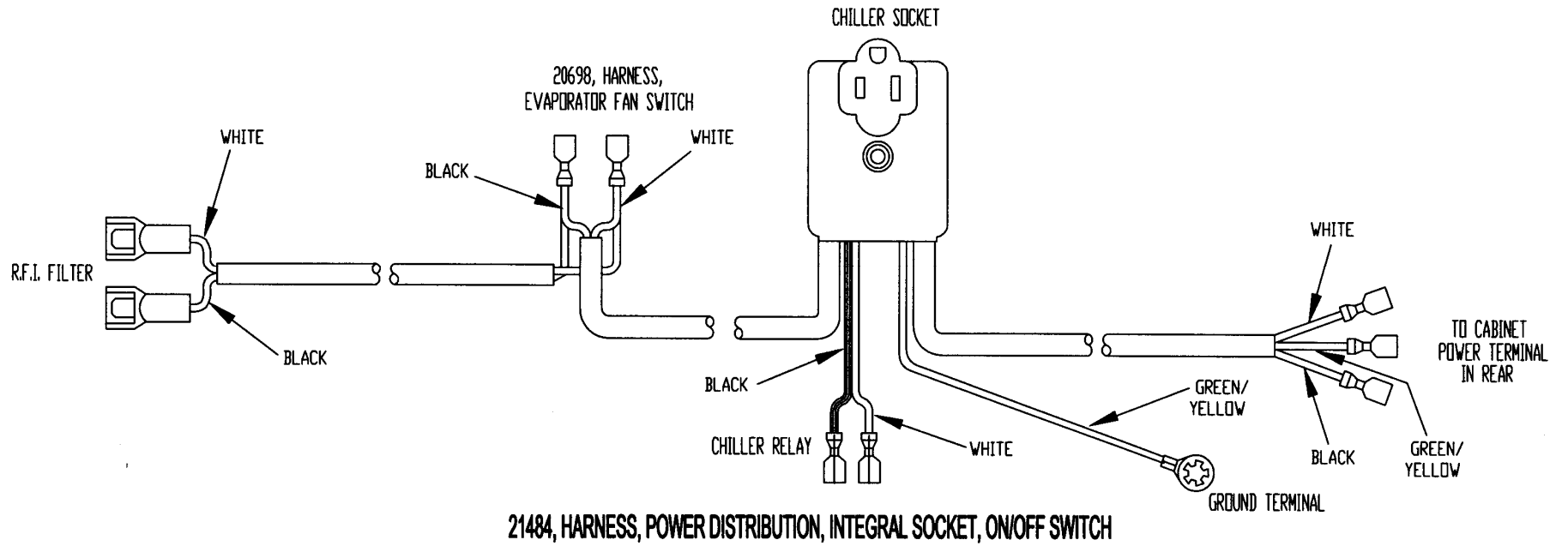

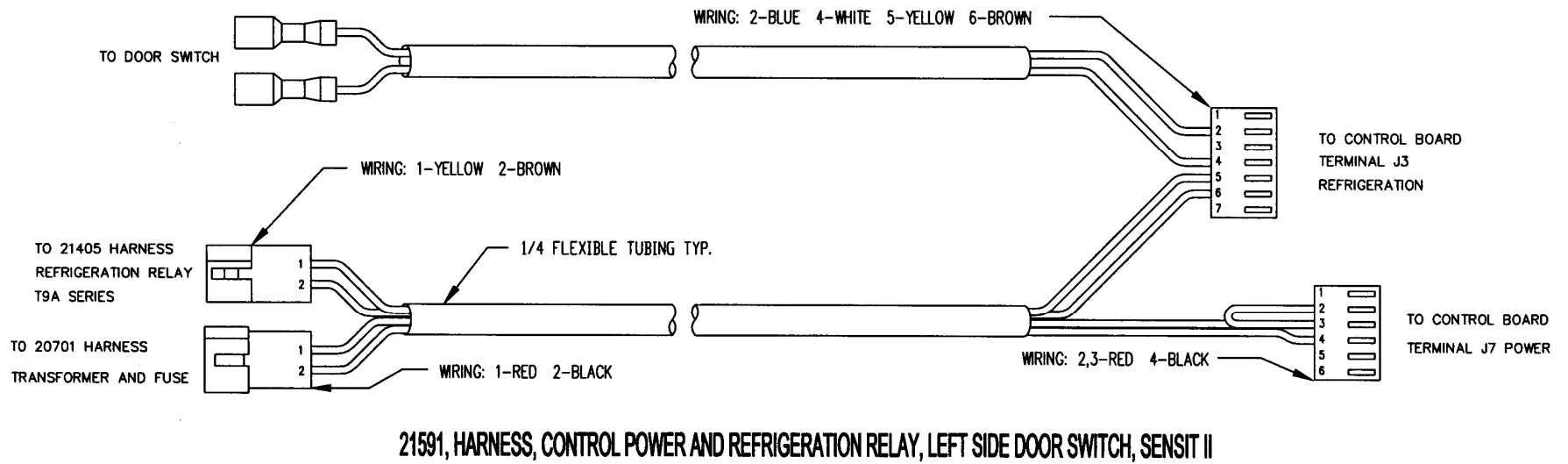
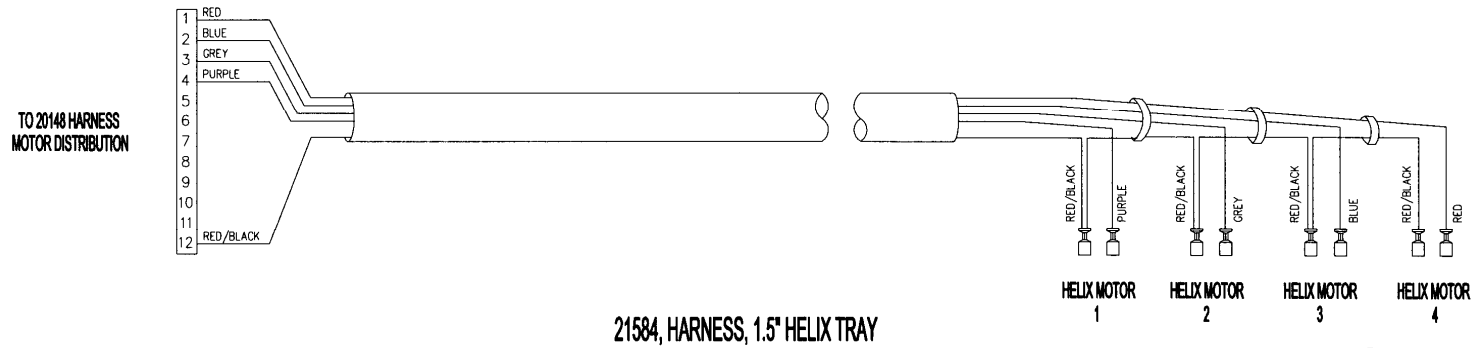

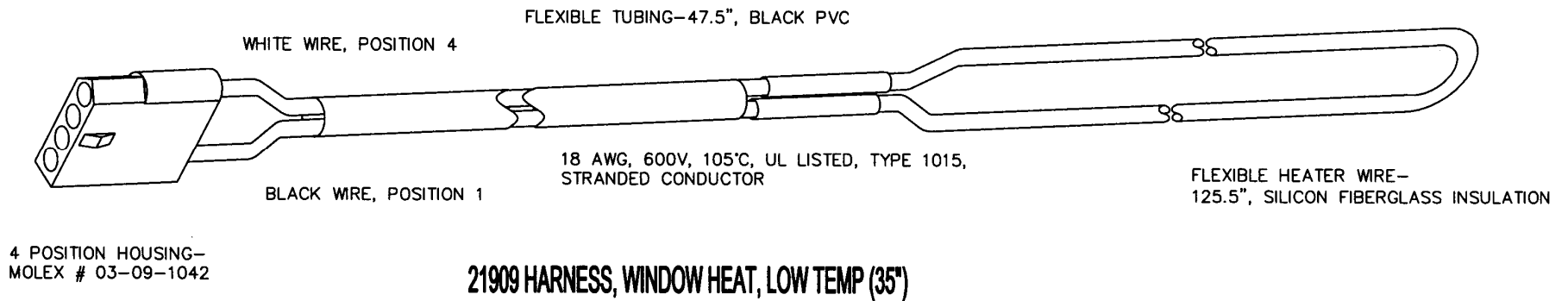
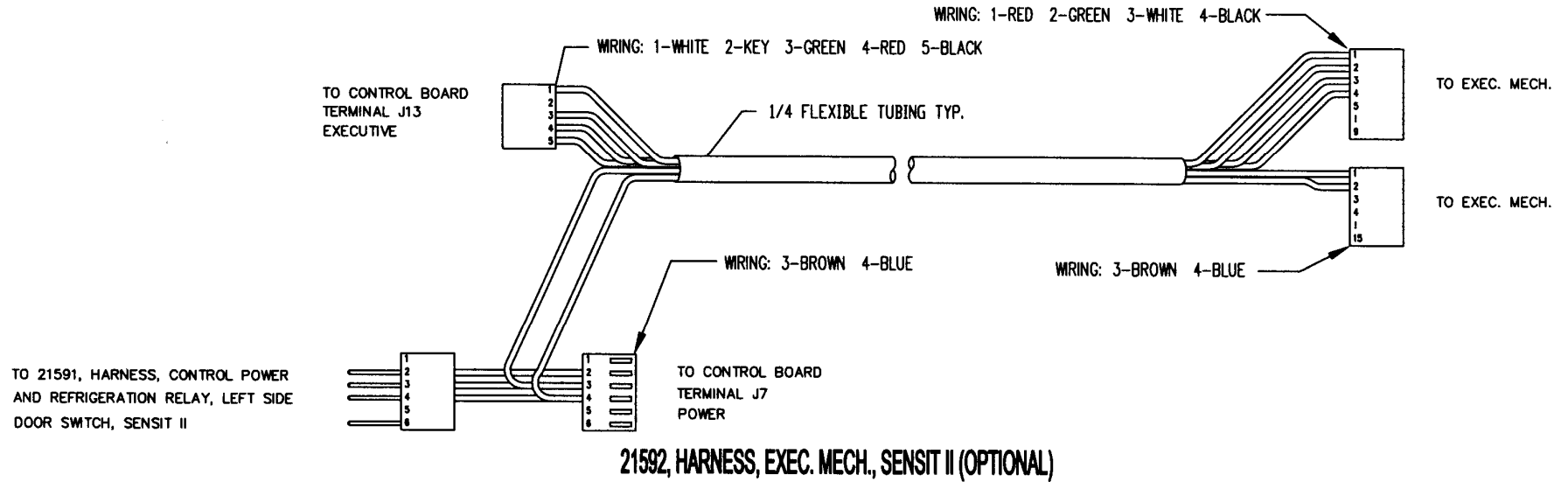

ELECTRICAL HARNESS PARTS LIST

PART NO.	PART DESCRIPTION	QTY	NOTES
20142	Power Cord Assembly, U.S.	1	U.S. Use
20144	Harness, Refrigeration, (Not Labeled)	1	For Chiller Power
20146	Harness, Door Motors	1	
20147	Harness, Tray, 10 Column	1	Use For 5 Column Tray
20148	Harness, Motor Distribution	1	
20154	Harness, R.F.I. Filter Ground	1	
20158	Harness, Multi-Drop Bus	1	
20163	Harness, Tray, 8 Column	1	Use For 4 Column Tray
20199	Keypad, Harness	1	Integral to Keypad
20563	Harness, Ballast, Assembly 2	1	VCB Option
20564	Harness, Lamp 2	1	VCB Option, Attaches to Lamp Bracket
20698	Harness, Evaporator Fan Switch	1	
20701	Harness, Transformer and Fuse	1	
20718	Harness, Dual Lamp, 110VAC	1	VCF Option
20730	Harness, Ballast, Dual Lamp, 110VAC	1	VCF Option, Attaches to Lamp Bracket
20897	Harness, Dual Transformer	1	
20899	Harness, Window Heater Transformer	1	
21405	Harness, Refrigeration Relay T9A	1	
21425	Harness, Delivery Sensor Detector/Control, Sensit II	1	
21426	Harness, Delivery Sensor Detector/Emitter, Sensit II	1	
21427	Harness, Product Sensor Emitter, Sensit II (Optional)	1	
21428	Harness, Product Sensor Detector, Sensit II (Optional)		
21432	Harness, Display, Sensit II	1	
21468	Temperature Sensor, and Harness, Sensit II	1	Integral to Sensor, for Chiller
21484	Harness, Power Distibution, Integral Socket, On/Off Switch	1	
21485	Harness, On/Off Switch	1	
21584	Harness, 1.5" Helix Tray	1	
21591	Harness, Control Power & Refrigeration Relay, Left Side Door Switch, Sensit II	1	
21592	Harness, Executive Mech Connector, Sensit II	1	
21909	Harness, Window Heat, Low Temp (35")	1	

THIS PAGE INTENTIONALLY LEFT BLANK

1.5" HELIX TRAY ILLUSTRATION

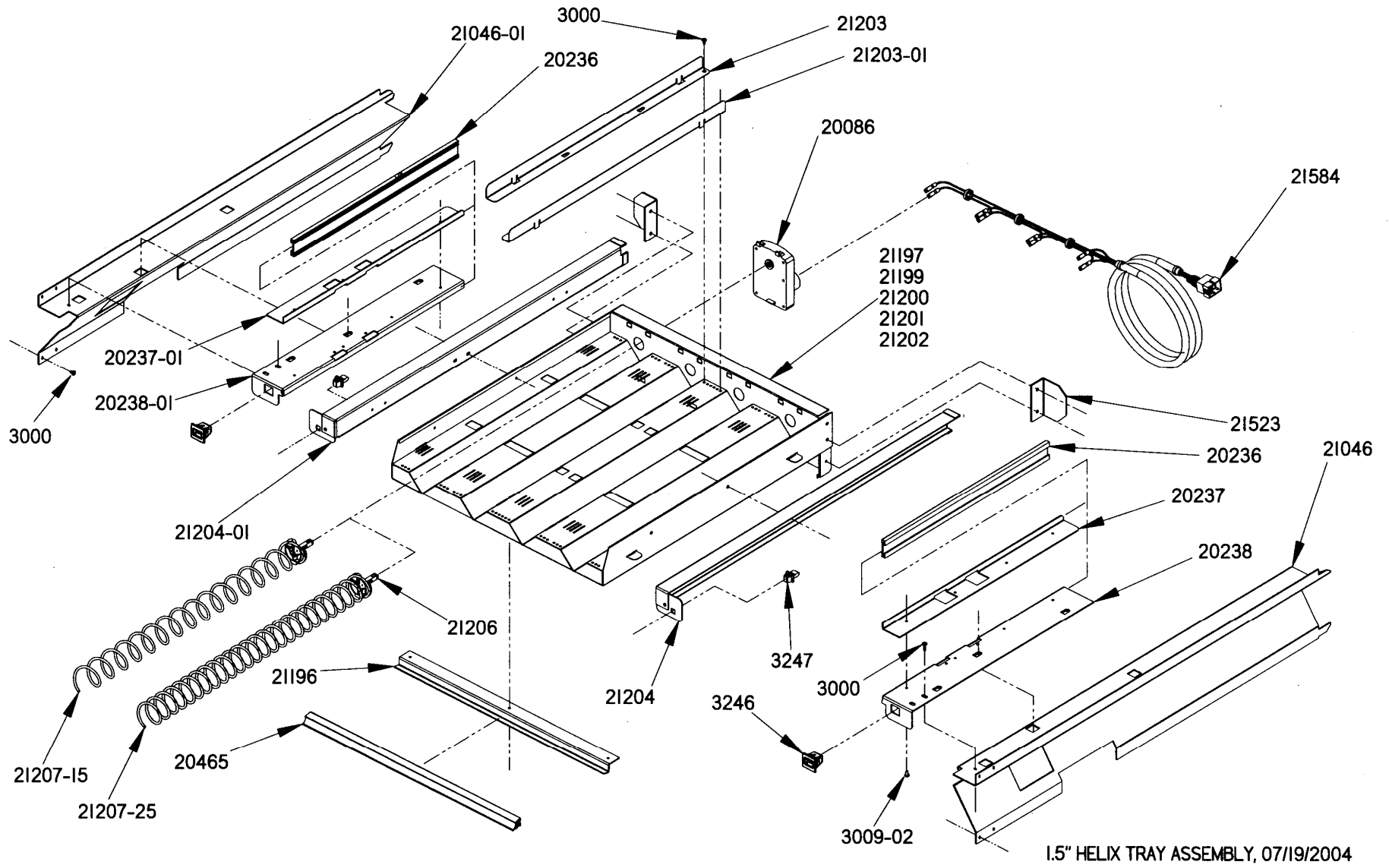

1.5" HELIX TRAY PARTS LIST			
PART NO.	PART NAME	QTY	NOTES
3000	Screw, TEK 8-18	18	
3009-02	Rivet, Pop, Steel, 1/8	34	
3246	Latch, Nylon, Gum and Mint	2	
3247	Strike, Nylon, Gum and Mint	2	
20086	Motor, Single Helix W/O Switch	4	
20236	Extrusion, Gum and Mint Rail	2	
20237	Extrusion Mount, Upper (Gum and Mint)(Right Side)	1	
20237-01	Extrusion Mount, Upper (Gum and Mint)(Left Side)	1	
20238	Extrusion Mount, Lower (Gum and Mint)(Right Side)	1	
20238-01	Extrusion Mount, Lower (Gum and Mint)(Left Side)	1	
20465-04	Extrusion, Price Marker, Reduced Height	1	
21046	Rail, Gum and Mint, Reduced Depth (35")(Right Side)	1	
21046-01	Rail, Gum and Mint, Reduced Depth (35")(Left Side)	1	
21196	Doubler, Tray 1.5" Helix Tray	1	
21197	Tray Body, 1.5" Helix Tray	1	Parts Are Factory Assembled As A Unit
21199	Tray Back, 1.5" Helix Tray	1	
21200	Tray Inner Side, 1.5" Helix Tray	2	
21201	Tray Inner Section, 1.5" Helix Tray	2	
21202	Tray Inner Mid Section, 1.5" Helix Tray	1	
21203	Divider, Tray, 1.5" Helix Tray, RH	4	
21203-01	Divider, Tray, 1.5" Helix Tray, LH	4	
21204	Tray Slide Channel, 1.5" Helix Tray, RH	1	
21204-01	Tray Slide Channel, 1.5" Helix Tray, LH	1	
21206	Helix Adapter, 1.5" Helix Tray	4	
21207-15	Helix, 1.5" Tray, Counterclockwise, Black	2	Standard Tray is Equipped With Two Of Each
21207-25	Helix, 1.5" Tray, Counterclockwise, Black	2	
21523	Bracket, Stop, 1.5" Helix Tray	2	
21584	Harness, 1.5" Helix Tray	1	

BOTTLE TRAY ILLUSTRATION

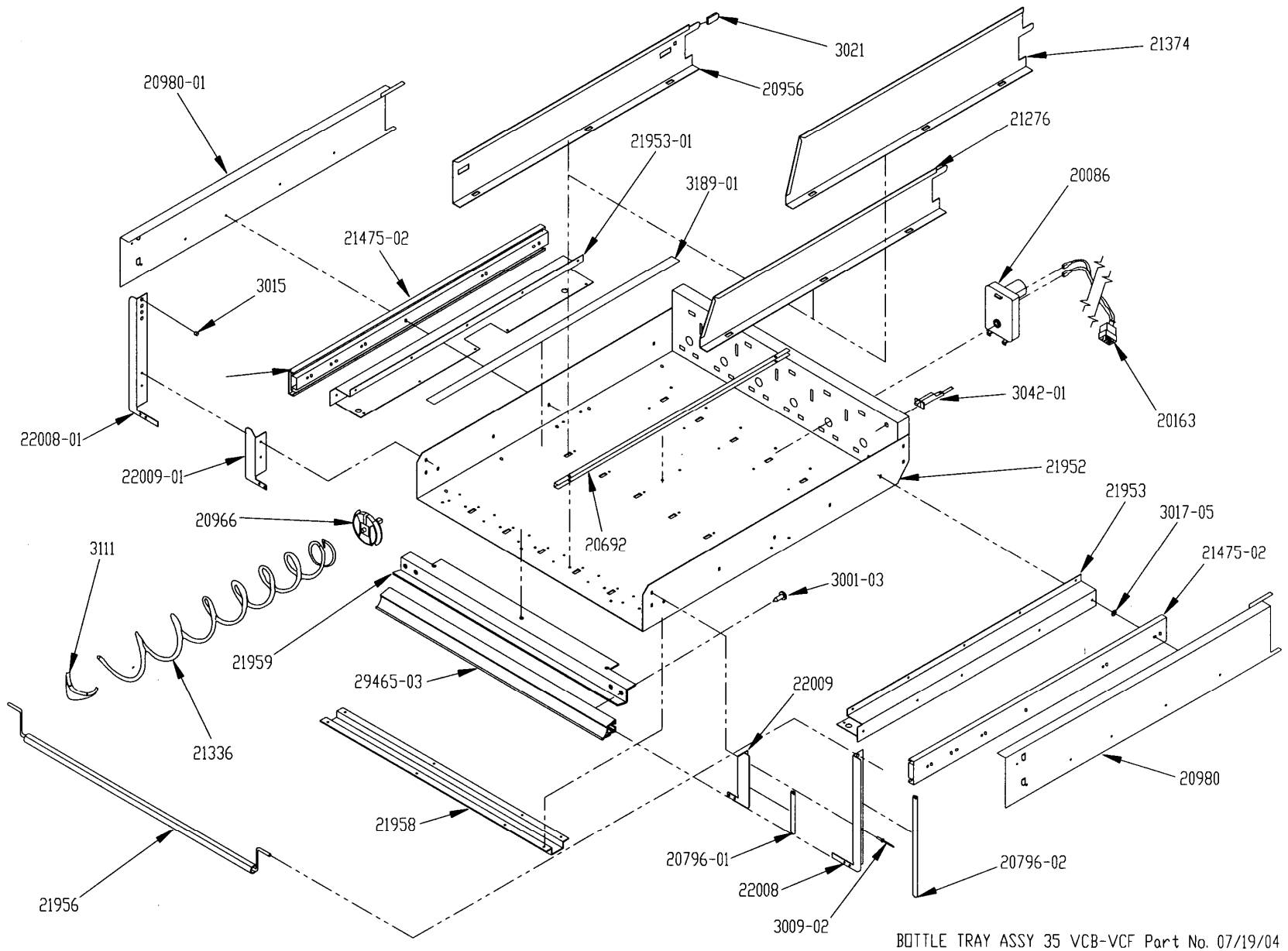

BOTTLE TRAY ASSY 35 VCB-VCF Part No. 07/19/04

BOTTLE TRAY PARTS LIST

PART NO	PART NAME	QTY	NOTE
3001-03	Screw, Sheet Metal, Type B, 8-18	6	
3009-02	Rivet, Pop, Steel, 1/8	81	
3015	Bearing, Nyliner, Snap-In	2	Use On Bottle Tipper
3017-05	Washer, Flat Steel	10	For Rivet Reinforcement on Rail Slides
3021	Protective Cap, Vinyl	5	
3042-01	Wire Tie, Panel Mount	1	
3111	Helix Ejector, Small Helix	6	
3189-01	Tape, UHMW Polyethylene, 3/4" X .005"	12'	
20086	Motor, Single Helix W/O Switch	6	
20163	Harness, Tray, 8 Column	1	
20465-03	Extrusion, Price Marker, Ver. 2	1	
20692	Device, Bottle Alignment	6	
20796-01	Edge Guard, Tray Corner (Only RH)	1	
20796-02	Edge Guard, Tray Corner (Only RH)	1	Use With Bottle Tipper
20956	Tray Divider, Reduced Depth (Square Front)	5	
20980	Rail, Bottle Tray, Reduced Depth (RH)	1	Use Lower Rivet Positions For Milk
20980-01	Rail, Bottle Tray, Reduced Depth (LH)	1	Use Lower Rivet Positions For Milk
20966	Helix Adapter, Without Hub	6	
21276	Tray Divider, Reduced Depth, Tapered Front	5	3.3" High
21336	Helix, 3" Counter-Clockwise, 3.5" Opening, Black	6	See Helix Description For Options
21374	Tray Divider, Reduced Depth, Tapered Front, High	5	4.9" High
21475-02	Rail Slide, Full Extension, 24"	1	1 Pair (1Slide Each for RH and LH)
21952	Tray Body, Bottle, Reduced Depth, Low Temp (35")	1	Customer Determines Set-up and Quantity
21953	Tray Bracket, Right Hand	1	
21953-01	Tray Bracket, Left Hand	1	
21956	Assembly, Bottle Tipper Bar, Low Temp (35")	1	
21958	Tray Reinforcement, Bottle, Low Temp (35")	1	
21959	Tray Doubler, Bottle, Low Temp (35")	1	
22008	Tray Corner, Bottle Tipper Bar, Low Temp (35")	1	
22008-01	Tray Corner, Bottle Tipper Bar, Low Temp (35")	1	
22009	Tray Corner, Bottle, Low Temp (35")	1	
22009-01	Tray Corner, Bottle, Low Temp (35")	1	

HELIX ILLUSTRATIONS

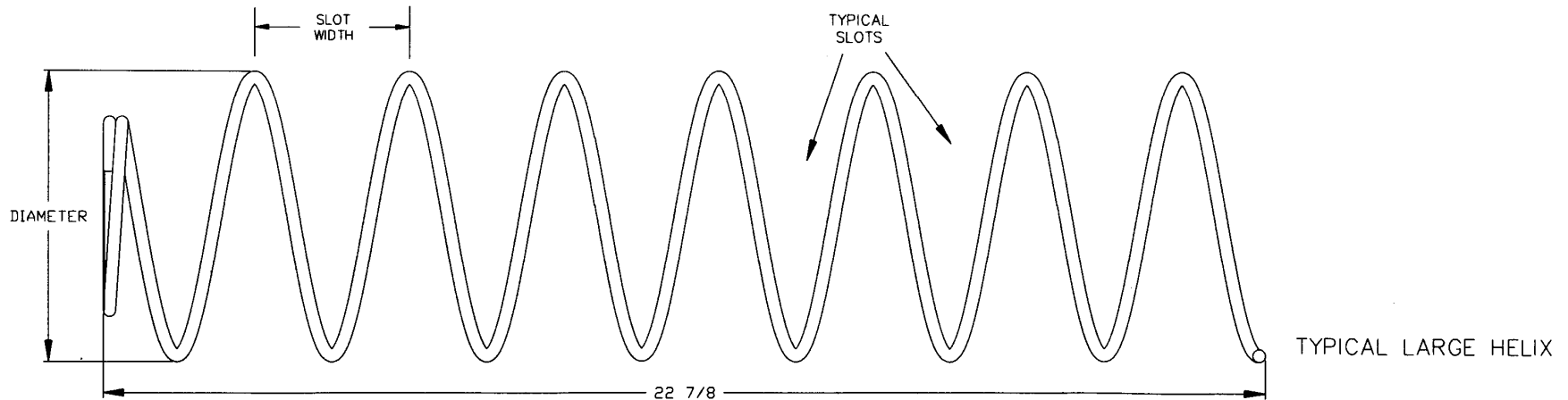
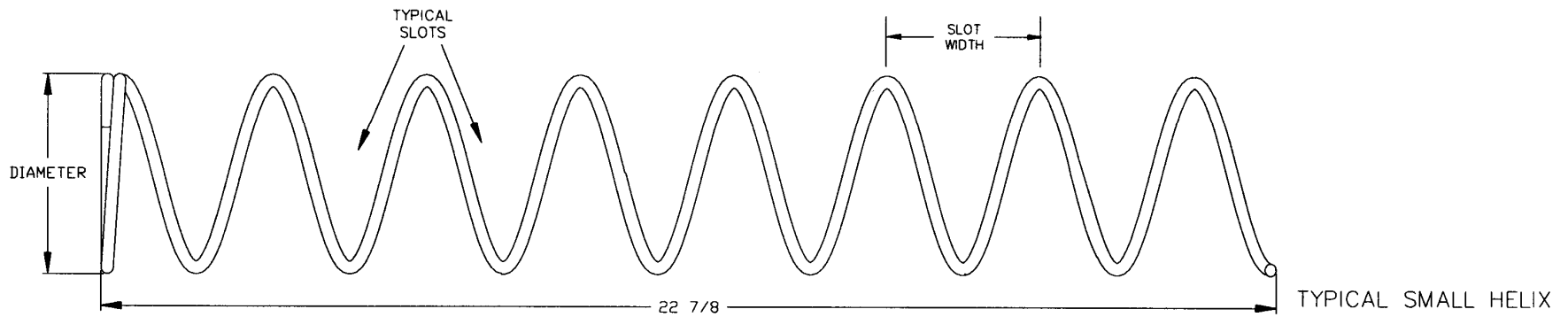
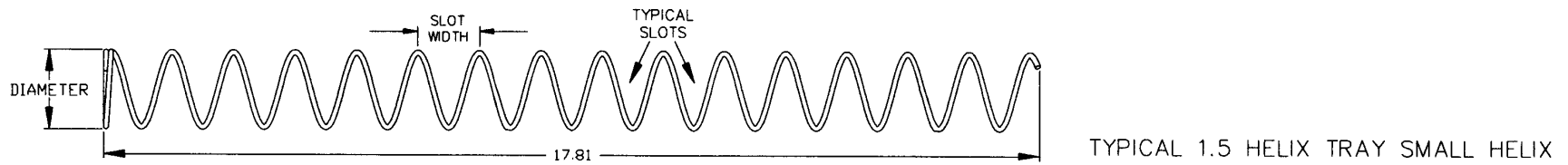

HELIX PARTS LIST

PART NO.	HELIX DESCRIPTION *	SLOT (VEND) WIDTH	NUMBER OF SLOTS (PITCH)	HELIX OUTSIDE DIAMETER	TURNS	QTY PER COLUMN	NOTE
20119-07	Helix, Small CW, Black	2 5/8	7	2.6	CW	1 Set	Use With 20120-07 As A Set
20120-07	Helix, Small CCW, Black	2 5/8	7	2.6	CCW	1 Set	
20119-10	Helix, Small CW, Black	1 7/8	10	2.6	CW	1 Set	Use With 20120-10 As A Set
20120-10	Helix, Small CCW, Black	1 7/8	10	2.6	CCW	1 Set	
20120-12	Helix, Small CCW, Black	1 7/8	12	2.6	CCW	1	
20120-15	Helix, Small CCW, Black	1 7/8	15	2.6	CCW	1	
20120-18	Helix, Small CCW, Black	1 7/8	18	2.6	CCW	1	
20120-24	Helix, Small CCW, Black	1 7/8	24	2.6	CCW	1	
21207-15	Helix, 1.5", CCW, Black	1	15	1.5	CCW	1	Use in 1.5" Helix Tray
21207-25	Helix, 1.5", CCW, Black	9/16	25	1.5	CCW	1	Use in 1.5" Helix Tray
21336	Helix, 3", CCW, Black	3.5	6	3	CCW	1	Bottle Tray
21337	Helix, 3", CCW, Black	3.2	6	3	CCW	1	Bottle Tray
21465-5	Helix, 3.75" CCW, Black	3 ¼	5	3.75	CCW	1	Large
21465-7	Helix, 3.75" CCW, Black	2 5/8	7	3.75	CCW	1	Large
21465-9	Helix, 3.75" CCW, Black	2	9	3.75	CCW	1	Large
21465-10	Helix, 3.75" CCW, Black	1 ¾	10	3.75	CCW	1	Large
21465-12	Helix, 3.75" CCW, Black	1 ½	12	3.75	CCW	1	Large
21465-15	Helix, 3.75" CCW, Black	1 ¼	15	3.75	CCW	1	Large

UNIVERSAL (FOOD/SNACK/CANDY) TRAY ILLUSTRATION

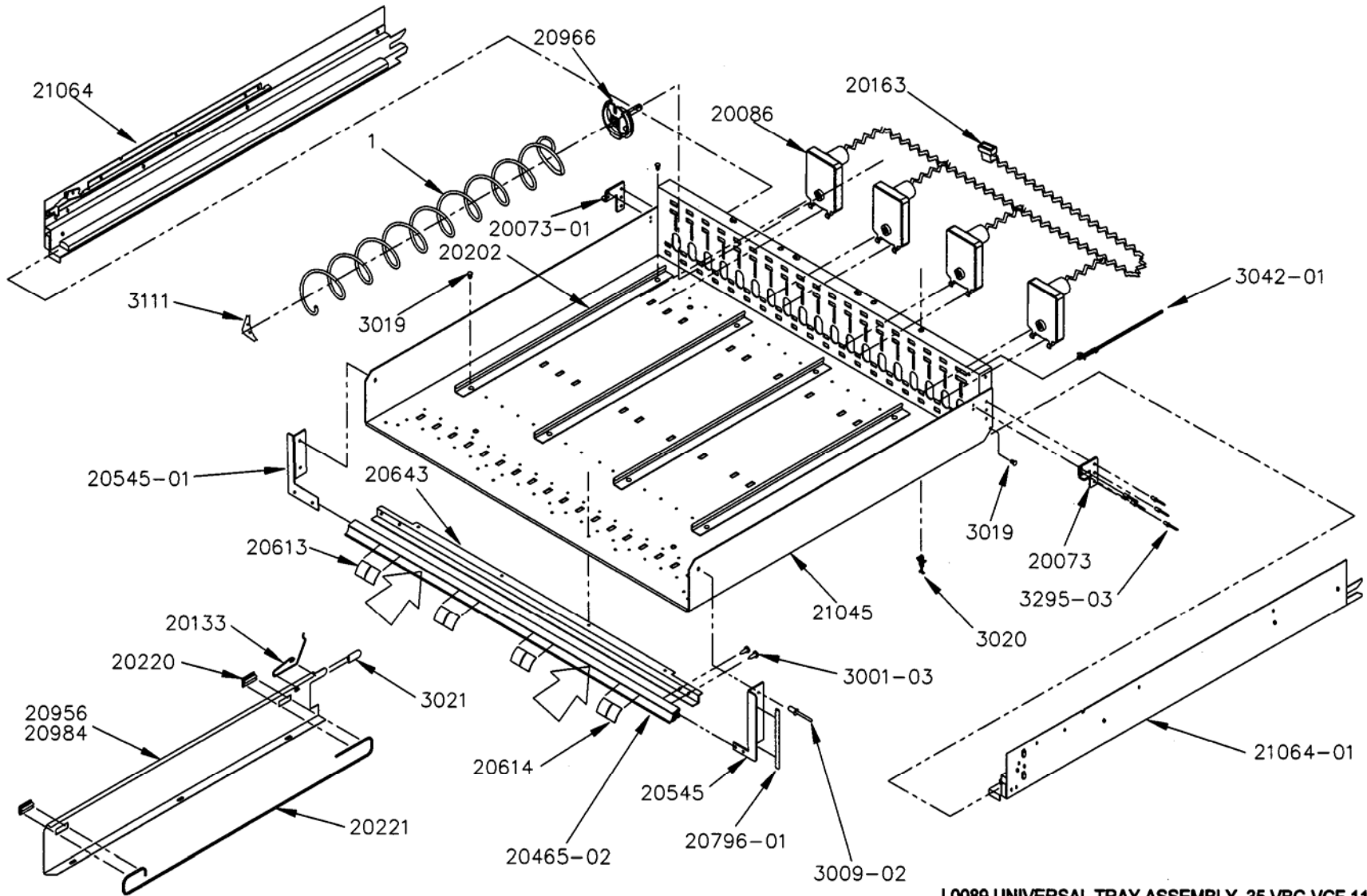

L0089 UNIVERSAL TRAY ASSEMBLY, 35 VBC-VCF 11/29/04

UNIVERSAL (FOOD/SNACK/CANDY) TRAY PARTS LIST

PART NO.	PART NAME	QTY	NOTE
-----	Helix	4	Customer Set-Up Determines Helixes
3001-03	Screw, Sheet Metal, Type B, #8-18 (3/8" Long)	4	
3009-02	Rivet, Pop, Steel, 1/8 (1/8" Grip)	12	
3019	Canoe Clip	10	
3020	Wire Tie, Standoff	1	
3021	Divider Cap	3	
3042-01	Wire Tie, Panel Mount	1	
3111	Helix Ejector	4	
3295-03	Rivet, Steel, 1/8", Plated	10	Use Only Steel Rivets for Tab
20073	Tray Stop (Rh)	1	
20073-01	Tray Stop (Lh)	1	
20086	Motor, Single Helix	4	
20133	Tray Divider Spring	3	
20163	Harness, Tray, 8 Column	1	Use for 4 column set-up
20202	Helix Alignment Device	4	Qty determined by set-up.
20220	Extrusion, Candy Pusher	6	
20221	Bar, Candy Pusher	3	
20465-02	Extrusion, Price Marker, Reduced Height	1	
20545	Tray Corner, Ver. 2 (Rh)	1	
20545-01	Tray Corner, Ver. 2 (Lh)	1	
20613	Label Sheet, Reduced Height Location	1	
20614	Label Sheet, Reduced Height Price	1	
20643	Tray Doubler, Ver. 2 (35")	1	
20796-01	Edge Trim, Tray Corner	1	Right Hand Corner Only
20956	Tray Divider, Reduced Depth	3	Select 3 Dividers
20966	Helix Adapter, Without Hub	4	
20984	Tray Divider, High, Reduced Depth	3	Select 3 Dividers
21045	Tray Body, Reduced Depth (35")	1	
21064	Assembly, Reduced Depth, Rail (RH)	1	
21064-01	Assembly, Reduced Depth, Rail (LH)	1	

